



MM

Rapid Sliding Trolley Door System

Maintenance Manual

Version	2.0
Release date	2022-08-03
Document ID	RS300022
Project name	Rapid Sliding Door System
Project ID	RS

We welcome millions
of people every day



Revision history

Revision	Date	By	Description
2.0	2022-08-03	Prepared: <i>M.Sandtmann</i>	-Change torquesetting position 3 to: 30 -2 +0 Nm. -Added loctite to torquesetting position 9.
1.0	2022-07-01	Prepared: <i>M.Sandtmann</i>	Initial release



Preface

The Quality System of Ventura Systems is accredited to IATF 16949:2016 and ISO 14001:2015.

All rights reserved. Disclosure to third parties of this document or any part thereof, or the use of any information contained therein for purposes other than provided for by this document, is not permitted, except with prior and express written permission from Ventura Systems.

Printed documents are uncontrolled. Documents are subject to change therefore verify correct revision before use.

Table of Contents

1 Introduction	6
1.1 Purpose.....	6
1.2 Scope	6
1.3 Definitions	6
1.4 Acronyms and Abbreviations	6
1.5 References.....	6
1.5.1 External documents.....	6
1.6 Overview.....	6
2 Door installation safety	7
2.1 General	7
2.2 Disclaimer	7
2.3 Safety alert symbols.....	8
2.4 Safety instructions	9
3 Maintenance.....	10
3.1 Safety parts.....	10
3.1.1 Lever block	11
3.1.2 Emergency release	12
3.1.3 Sensitive edge	13
3.1.4 Micro switches (Switch & Cams).....	14
3.1.5 Obstruction detection unit.....	15
3.2 Wear parts.....	16
3.2.1 Overcenter soft stopper	16
3.2.2 Door closed soft stopper	16
3.2.3 Door open soft stopper	17
3.2.4 Guide rollers.....	18
3.2.5 Bottom soft stopper	19
3.2.6 Top soft stopper	19
3.3 Parts inspections	20
3.3.1 Door shaft.....	20
3.3.2 Filter regulator	21
3.3.3 Clamping force test.....	22
3.3.4 Grease bearing house.....	23
3.3.5 Grease spiral cable guiding shaft	23
3.3.6 Trolley insulation parts	24
4 Torque Settings	27
5 Operational checks.....	29
5.1 Operation and controls.....	29
5.2 Safety checks	29
6 Contact.....	30

List of Figures

Figure 1: Lever block	11
Figure 2: Dismount the door leaf	13
Figure 3: Disconnect the sensitive edge connectors	13
Figure 4: Door open micro switch	14
Figure 5: Door closed micro switch	14
Figure 6: connect multimeter to the obstruction detection unit	15
Figure 7: OverCenter Stopper	16
Figure 8: Door closed Stopper	16
Figure 9: Door open Stopper	17
Figure 10: Bottom guide rollers.....	18
Figure 11: Top guide roller.....	18
Figure 12: Clearance rail to lever bottom	18
Figure 13: Clearance rail to lever top	18
Figure 14: Bottom soft stoppers.....	19
Figure 15: Top soft stoppers	19

Figure 16: Bearing point top	20
Figure 17: Bearing point bottom	20
Figure 18: Filter regulator	21
Figure 19: Regulator	21
Figure 20: Obstruction test setup.....	22
Figure 21: View of the mechanism	23
Figure 22: Spiral cable guiding shaft.....	23
Figure 23: Insulation parts overview.	24
Figure 24: Doorarm insulation	24
Figure 25: Connection rod insulation	25
Figure 26: Top doorshaft insulation	25
Figure 27: Lock insulation	25
Figure 28: Bottom doorshaft insulation	25
Figure 29: Bottom support insulation	26
Figure 30: mark the fasteners with a torque marker.	27
Figure 31: torque setting overview.	27
Figure 32: World map Ventura locations	30

List of Tables

Table 1: Definitions	6
Table 2: Acronyms and abbreviations	6
Table 3: External documents	6
Table 4: Maintenance frequencies	10
Table 5: General contact information	30
Table 6: Parts contact information	30

1 Introduction

1.1 Purpose

This maintenance manual describes maintenance and small adjustment procedures for the Ventura trolley rapid slide door system. Together with the Installation manuals and system drawings makes a complete set of maintenance documentation. It is important to follow all instructions. All instructions must be conducted without air/electric power unless mentioned otherwise. The instructions should be executed for the left and right door leaf when the system contains two door leaves. A well-adjusted door system is less vulnerable to failure. The right maintenance is crucial for the durability of the door system.

1.2 Scope

The purpose of this document is to guide trained service mechanics through the maintenance steps of the trolley rapid slide door system. When repairs have to be made, the mechanic needs to use the repair manual, or the proper service instruction.

1.3 Definitions

Definition	Description
Wear part	Wear is progressive damage to a part caused by relative motion with respect to another substance or part.
Safety part	A safety part is a part, which is important to the overall safety of a system.

Table 1: Definitions

1.4 Acronyms and Abbreviations

Abbreviation	Description
DCU	Door Control Unit
HQ	Headquarters
IATF	International Automotive Task Force
IM	Installation Manual
ISO	International Standardization Organization
REG	Regulation
RS	Rapid Slide
PSI	Pound-force per Square Inch

Table 2: Acronyms and abbreviations

1.5 References

1.5.1 External documents

Reference	Description	Date
IATF 16949:2016	Automotive quality management system standard	2016-10-01
ISO 14001:2015	Environmental management systems – Requirements with guidance for use	2015-10-01
ISO 9001:2015	ISO Standard for Quality Management Systems – Requirements.	2015-10-01

Table 3: External documents

1.6 Overview

The list below shows a brief overview of the contents each chapter:

1. Gives an introduction, definitions and overview of this document.
2. Contains the general door system safety instructions, safety symbols and disclaimer.
3. Contains the maintenance instructions.
4. Contains the torque settings.
5. Contains operational checks before applying power.

2 Door installation safety

2.1 General

Safety of the operator and bystanders is one of the main concerns in designing and developing a new piece of equipment. Ventura's door systems have the proper safety features for common use of the system. An accident can often be avoided by recognizing potentially hazardous situations before an accident occurs. As you install, operate, or maintain the door system, you must be alert to potential hazards. Make sure you have the necessary training, skills and tools to perform any assembly, or maintenance procedures. Improper operation and maintenance of this door system may result in a dangerous situation that may cause injury or death.

Ventura Systems cannot anticipate every possible circumstance that may involve a potential hazard. The warnings in this document and on the product are not all-inclusive. If a method of installation or operation is used, which is not specifically recommended by Ventura Systems, you must satisfy yourself that it is safe for you and for others. You should also ensure that the door system will not be damaged or be made unsafe by the installation and/or operational methods you choose. The information, specifications and illustrations in this document are based on the information that was available at the time this document was written and can change at any time without notice.

2.2 Disclaimer

The information contained in this maintenance document is based upon reliable technical data at the time the document was published. These instructions are intended for use by persons having the technical knowledge to maintain this door system. The instructions are to be used at the maintenance mechanic's own discretion and risk. Ventura Systems assumes no responsibility for results obtained or damage incurred from the use of this material either in whole or in part by the installer. This document provides basic instructions for the maintenance of the door system in a step-by-step sequence that will work in most types of maintenances. While effort has been made to ensure the information in this document is correct and complete, we would appreciate it if you would contact us in case of errors.

2.3 Safety alert symbols

This document contains safety messages which alert you to potential personal injury hazards. Obey all safety messages in this document to avoid possible injury or death. The following key words and layouts calls for your attention: DANGER, WARNING, CAUTION and NOTICE. Below are examples of these safety messages. The NOTE message is used for additional information but these are not threatening for the mechanic, bystanders, nor the door system.



DANGER!

Indicates an imminently hazardous situation which, if not avoided, will result in death or serious injury. This signal word is limited to the most extreme situations.



WARNING!

Indicates a potentially hazardous situation which, if not avoided, could result in death or serious injury.



CAUTION!

Indicates a potentially hazardous situation which if not avoided, may result in minor or moderate injury.

NOTICE

Indicates that equipment or property damage can result if instructions are not followed.

NOTE

Additional information important but not threatening for people or to the system.

2.4 Safety instructions



DANGER!

Make sure the bolt, washers and insulations are fastened in the correct order. Doing this incorrectly could damage the insulation and compromise the safety of the passengers.



WARNING!

This door system is designed for a specific application;

DO NOT modify or use this unit for any application other than for which it was designed.

Door systems operated improperly or by untrained personnel is dangerous. Lack of operation knowledge may cause high risk.

Do not install this door system if it is damaged. If you are in doubt if the door system has a defect, immediately stop the installation and contact Ventura Systems.

Do not connect the door system to air or electric supply during the maintenance process. If the manual states otherwise, follow the manual.

Do not attempt to install the door system under influence of drugs or alcohol.

NOTICE

Do not modify the door system or safety devices. Unauthorized modifications may impair its function and safety.

If equipment has been altered in any way from the original design, Ventura Systems does not accept any liability for injury or warranty.

If replacement of parts is necessary, genuine factory replacement parts must be used to restore the door system to its original specifications.

*always disconnect the air and/or electric power while replacing parts. Safety features may not be active while replacing parts.

Ventura Systems will not accept responsibility for damages as a result of the use of unapproved parts.

While working on the Ventura door systems wear appropriate personal protective equipment.

This list may include but is not limited to:

- Protective shoes with slip resistant soles
- Protective goggles, glasses or face shield
- A hard hat

Follow the regional and country laws and safety precautions.

3 Maintenance

Maintenance of a door system should only be performed when the bus is positioned on a flat surface to prevent distortion/twisting of the bus body, which can lead to inaccurate measurements of the portal.

Whenever the amount of cycles is past, we advise to execute the applicable maintenance. At the table below, we address the chapter names.

Cycles assumption	Minimal maintenance	Applicable for
75.000	Every 3 months	Safety parts Operational checks
150.000	Every 6 months	Wear parts
300.000	Every 12 months	Parts inspections

Table 4: Maintenance frequencies

Execute at least the minimal maintenance intervals.

NOTICE

After maintenance has been completed, the settings must be applied as described in the commissioning manual. Be aware to use the commissioning manual that came with this product.

3.1 Safety parts

The checks in this chapter are safety critical. If these parts are not installed correctly, it can have great consequences for the safety of the system. When the system has two door leaves, the checks must be executed for both sides.

Ventura Systems recommend to execute all safety checks regularly and at least according to the maintenance intervals mentioned in the table [Maintenance frequencies](#).

3.1.1 Lever block

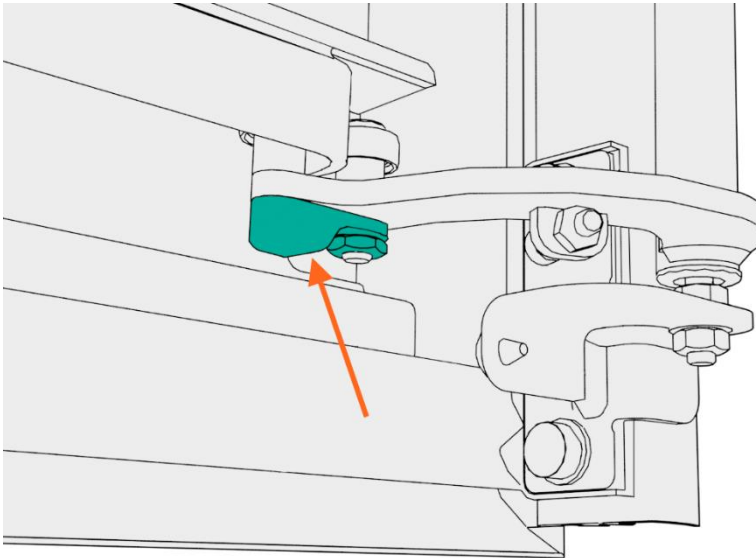

Figure 1: Lever block



WARNING!

When the lever block is not in place, the door leaf could get off the guiding roller when twisted, leading to situations with a high risk of injury to persons. It is very important the lever block is in place.

1. Check if the lever block is present at the bottom of the lever.
2. Check if the lever block is in the right position. It has to be inside the rail of the door leaf.
3. Check if the bolt is on torque following the installation manual.

3.1.2 Emergency release

The emergency release is not always supplied by Ventura. In case the emergency release is supplied by Ventura, execute the following check.

Apply power and/or pressure to the system and put the door(s) in closed position.



CAUTION!

Be aware the system could move when applying power and/or pressure to the system.

1. When the system is active, activate the emergency release.
The following events should occur.
2. The power/pressure is released from the system.
3. The door(s) can be opened manually.
 - Reset the emergency release.
 - Open and close the door(s) using the power source.



WARNING!

Remove the power and/or pressure from the system after executing this step and before you continue.

3.1.3 Sensitive edge

Apply power and/or pressure to the system and put the door(s) in closed position.



CAUTION!

Be aware the system could move when applying power and/or pressure to the system.

Do not use body parts to apply an obstruction.

- Put the door(s) in open position
- Close the door(s) and apply an obstruction in the closing motion at a height of 1 meter or less. Do not use body parts for this obstruction.
- The door goes to open position.

When the door leaf does not open when pressing the mid seal as described, perform the following checks or execute the repair instruction.

Disconnect the sensitive edge.

- Remove the bolts which connect the door leaf to the door arm.
 - Disconnect the connector from the spiral cable.
- The full door leaf could be removed to continue or a second engineer needs to hold the door, while executing the checks.**
- Connect a multimeter to the connector of the sensitive edge. Pin 1 and pin 7.

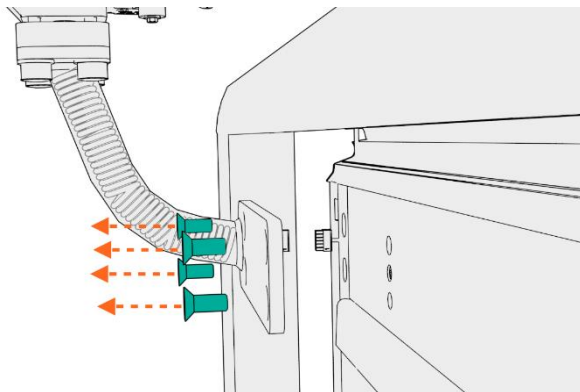

Figure 2: Dismount the door leaf

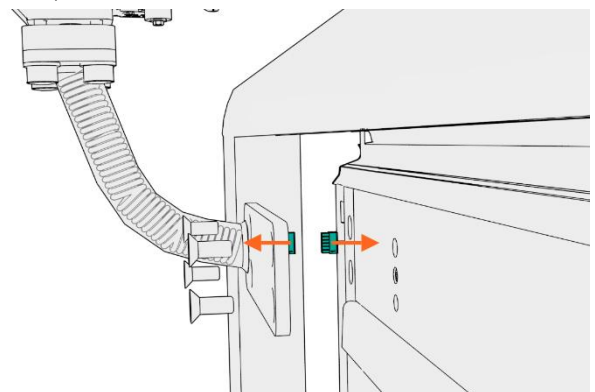

Figure 3: Disconnect the sensitive edge connectors

1. Be sure there is no force pressing the mid seal which can activate the sensitive edge. Resistance is 1200 or 8200 Ω depending on the resistor of the sensitive edge.
2. Apply force onto the mid seal of the door leaf. Resistance is approximately 0. $\sim 0 \Omega$

In case all checks are approved, reinstall the door leaf.

Follow the adjustment steps in the installation manual. Redo the calibration procedure described in the installation manual.

NOTE

The sensitive edge is malfunctioning when the resistance is infinite. $\infty \Omega$.



WARNING!

Remove the power and/or pressure from the system after executing this step and before you continue.

3.1.4 Micro switches (Switch & Cams)

The micro switches are optional. When the door system has one or more micro switches do the following checks. When the door system has no micro switches, skip this step.

If the system has one or more micro switches, apply power and/or pressure to the system and put the door(s) in closed position.



CAUTION!

Be aware the system could move when applying power and/or pressure to the system.

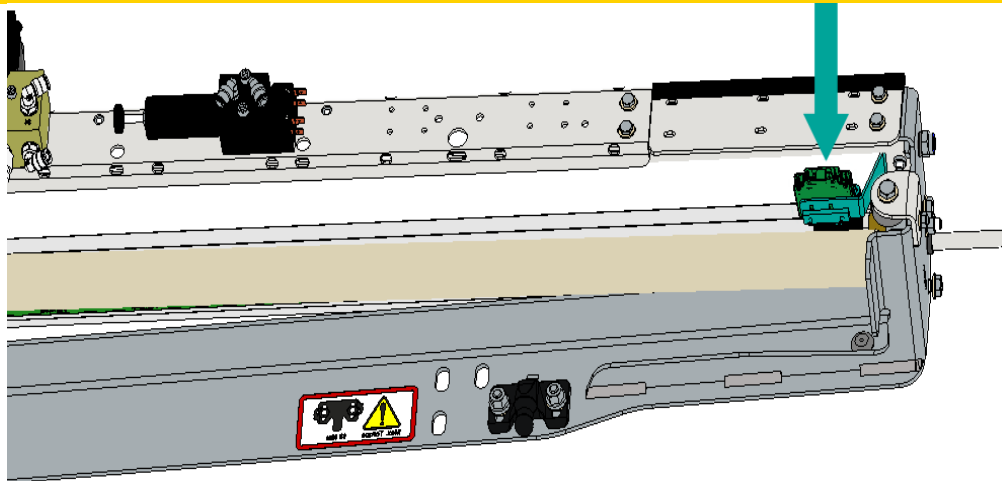

Figure 4: Door open micro switch

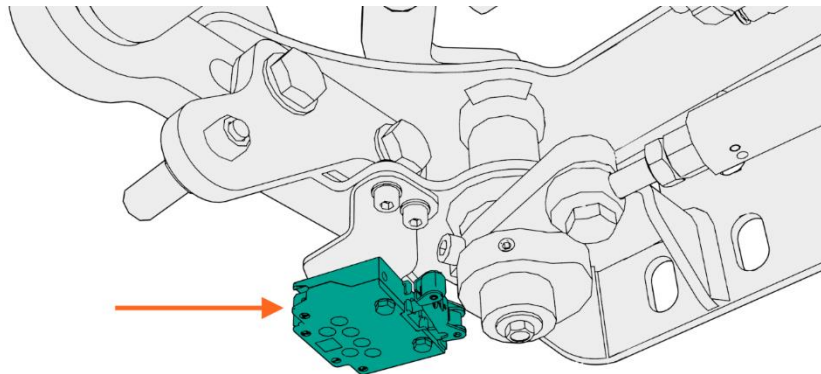

Figure 5: Door closed micro switch

1. When the doors are in open position, the micro switch open has to be activated. This micro switch is not adjustable.
2. When the door leaf is closed, and the top lever is ~2mm before hitting the end stop, the micro switch needs to be activated.

When the door closed micro switch is not activated when it is supposed to, readjust the cam following the installation manual.

3.1.5 Obstruction detection unit

Only applicable for pneumatic systems.

Apply power and/or pressure to the system and put the door(s) in closed position.



CAUTION!

Be aware the system could move when applying power and/or pressure to the system.

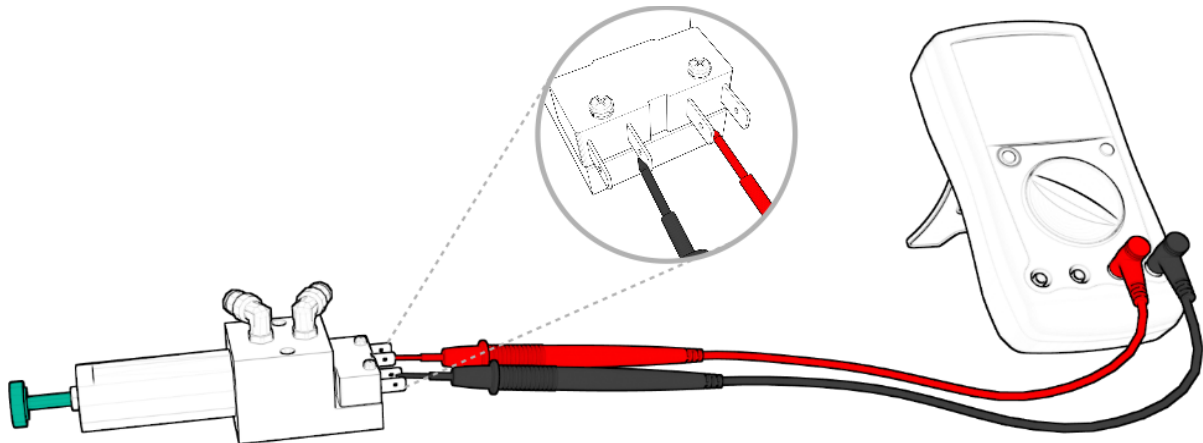

Figure 6: connect multimeter to the obstruction detection unit

1. If a signal is measured, the obstruction detection unit works properly.



WARNING!

Remove the power and/or pressure from the system after executing this step and before you continue.

3.2 Wear parts

These parts wear out and must be replaced when damaged, worn, after the prescribed cycles or after the prescribed time the parts are in usage. When a part has an amount of maximum cycles, it will be mentioned.

3.2.1 Overcenter soft stopper

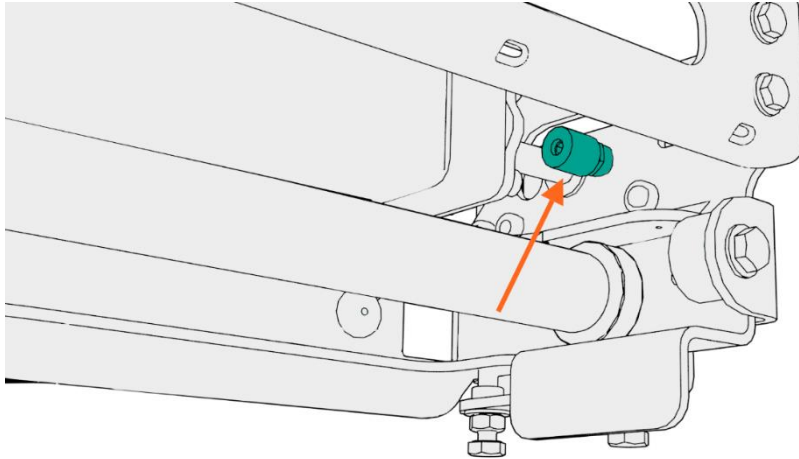

Figure 7: OverCenter Stopper

1. Check if the overcenter soft stoppers are present.
2. The overcenter soft stoppers are not damaged or worn.

3.2.2 Door closed soft stopper

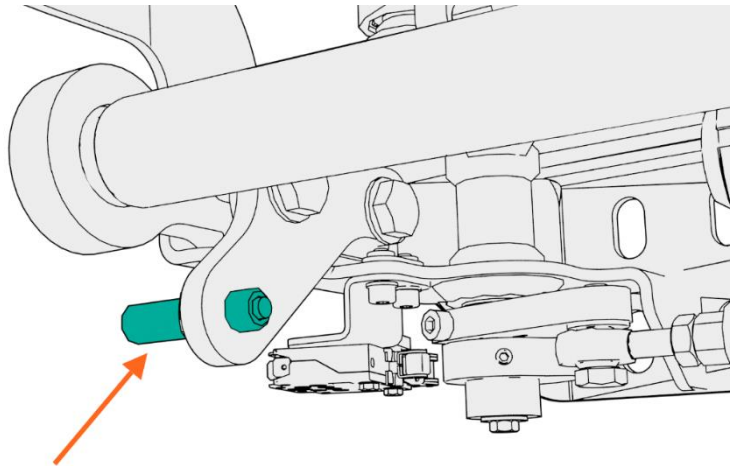

Figure 8: Door closed Stopper

1. Check if the door open stopper on the mechanism is present.
The soft stopper is the little rubber tip at the end.
2. The soft stopper is not damaged or worn.

3.2.3 Door open soft stopper

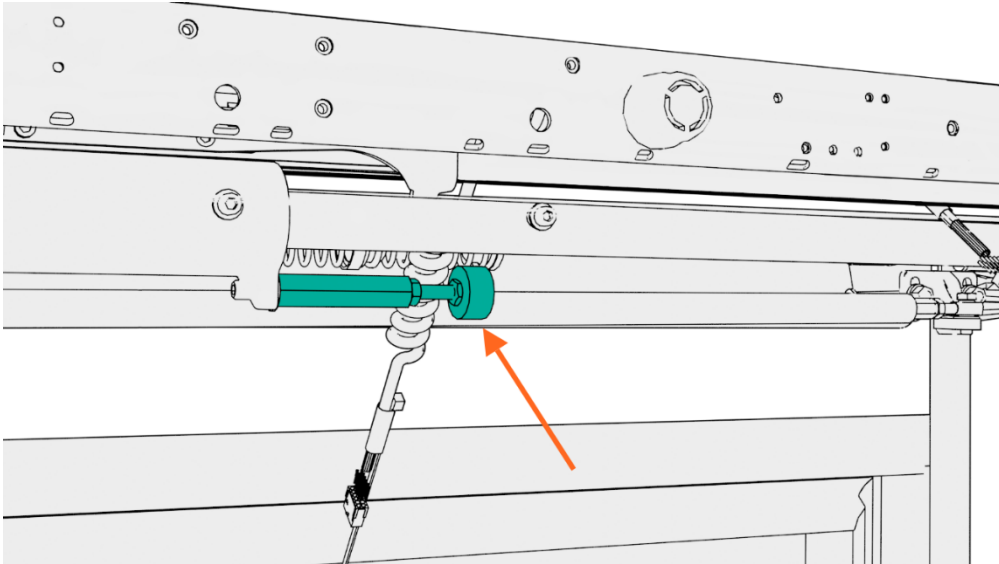

Figure 9: Door open Stopper

1. Check if the soft stopper on the bearing house is present.
2. The soft stopper is not damaged or worn.

3.2.4 Guide rollers

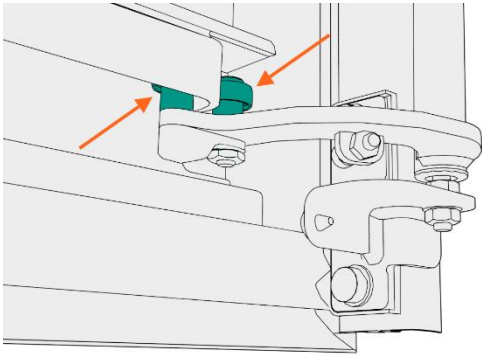

Figure 10: Bottom guide rollers

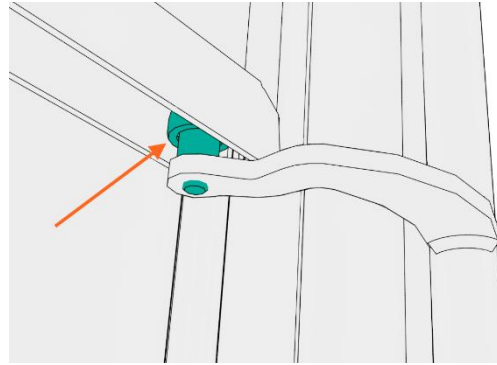

Figure 11: Top guide roller

1. The guide rollers on the lever(s) are not worn or damaged in any way. Check for damage visually and feel if there are no worn places on the guide rollers.
The guide rollers are located at the bottom lever and at the top lever.
2. The clearance between the bottom lever and the guiding rail is the same as described in the installation manual over the full length of the door movement.
If the clearance is not the same, adjust the height of the door shaft following the installation manual.

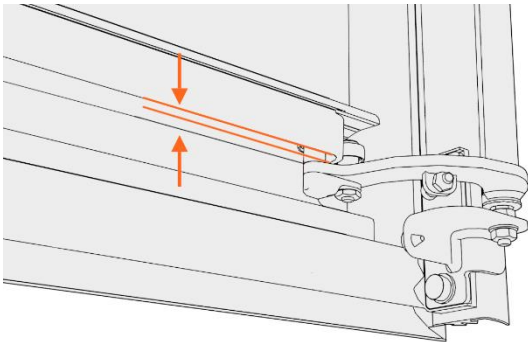

Figure 12: Clearance rail to lever bottom

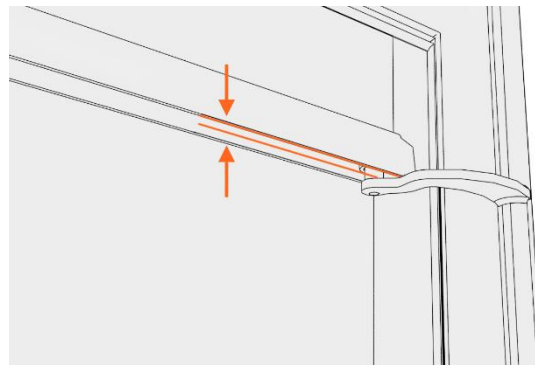

Figure 13: Clearance rail to lever top

3.2.5 Bottom soft stopper

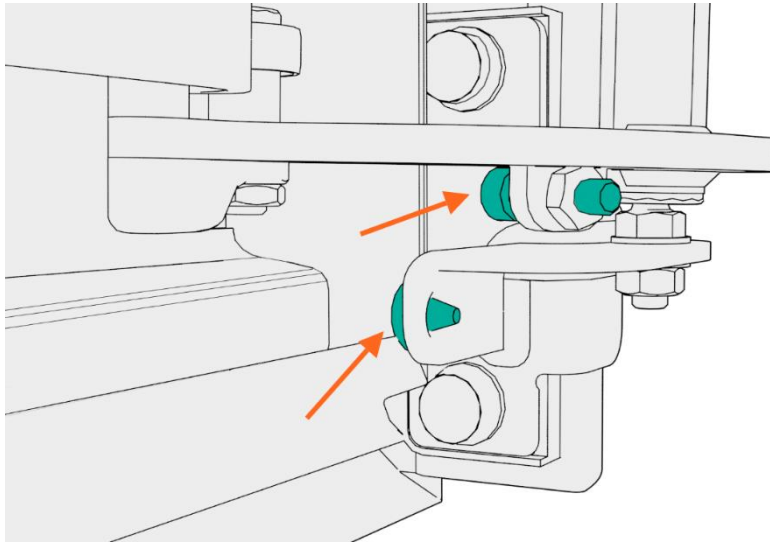

Figure 14: Bottom soft stoppers

1. Check if the bottom soft stoppers are present.
2. The bottom soft stoppers are not damaged or worn.
 - When the soft stopper needs to be replaced, follow door leaf adjustments following the installation manual.

3.2.6 Top soft stopper

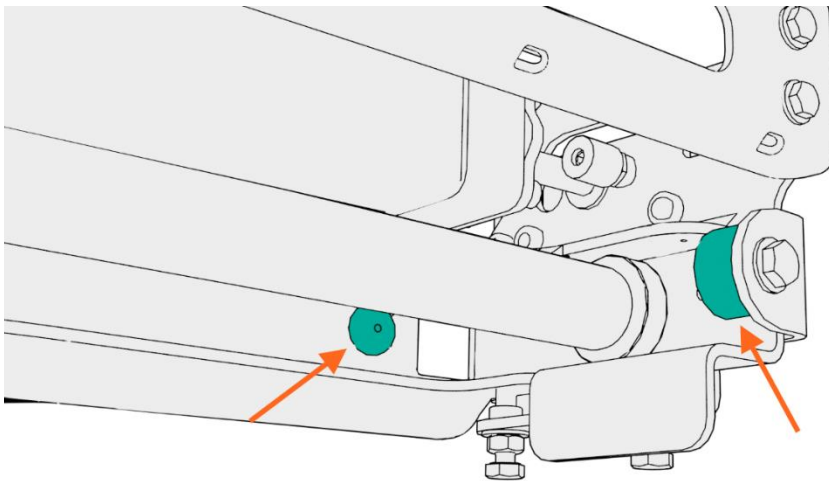

Figure 15: Top soft stoppers

1. Check if the top soft stoppers are present.
2. The top soft stoppers are not damaged or worn.
 - When the soft stopper(s) needs to be replaced.

3.3 Parts inspections

These parts can get affected by usage and must be re-adjusted or cleaned when needed. Check the distance settings of the door system in open and closed position following the installation manual. Check the torque settings of the door system following the installation manual.

3.3.1 Door shaft

- Check if the door shaft is free from vertical play (up and downward movement).

If the door shaft is free from vertical play, continue without executing this step. If there is play, execute the following checks.

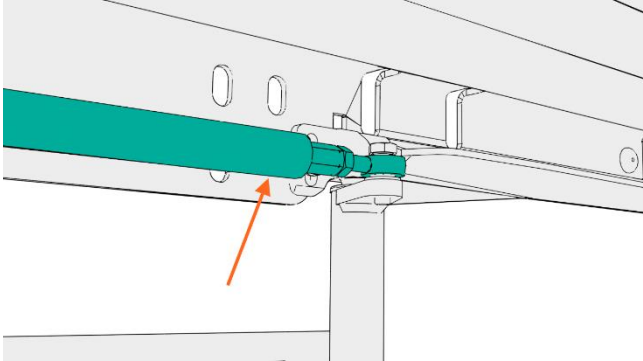

Figure 16: Bearing point top

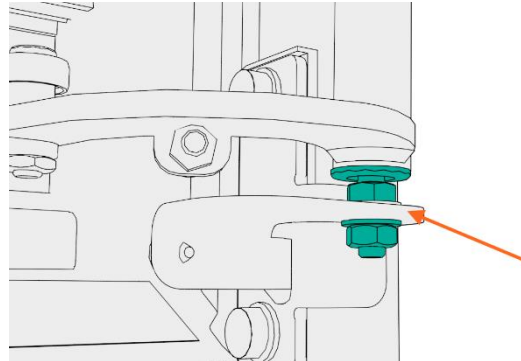

Figure 17: Bearing point bottom

1. Check the settings following the installation manual.
2. The bearing bush and pivot point at the bottom of the door shaft are not worn or damaged.
3. The bearing bush and pivot point at the top of the door shaft is not worn or damaged.

3.3.2 Filter regulator

Check if the system is equipped with a regulator or a filter regulator. If there is no regulator or a filter regulator, skip this step.

1. Check if the pressure of the pneumatic system is 8* bar.
*in case of an electric system with a non-Ventura DCU,
check if the pressure of the pneumatic system is 6 bar.
2. The filter regulator is semi-automatic, meaning the filter will drain itself when the pneumatic pressure drops below 0.3 bar (4.3 PSI) and the drain is open.
3. Replace the filter when it is not clear white.

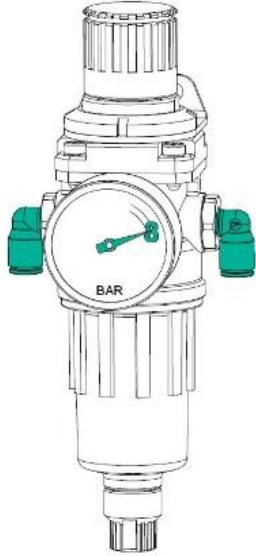

Figure 18: Filter regulator

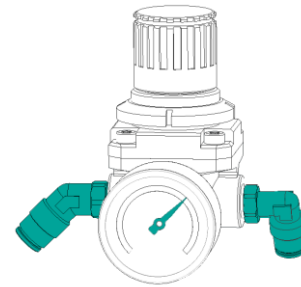

Figure 19: Regulator

Open drain by turning clockwise
Close drain by turning counter clockwise

NOTICE

Depending on the filter regulators location, it is advised to keep the drain closed so it will not spill dirt over vital parts of the bus.

3.3.3 Clamping force test

Be assured all safety features of the system are active. Execute the obstruction test following the applicable regulations for your company. (Regulations Ventura meets are REG107, TS155)

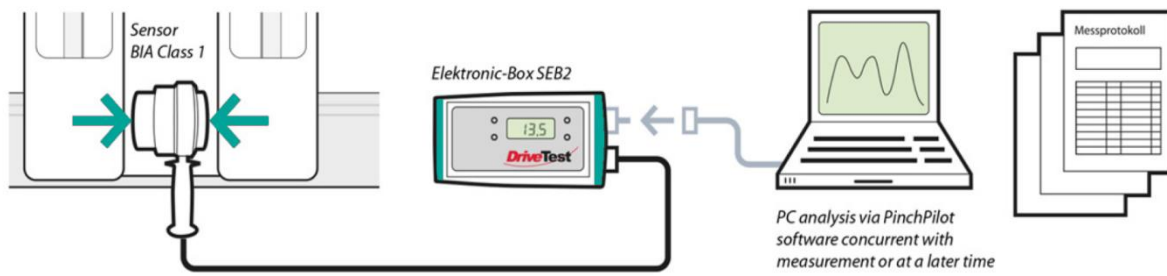

Figure 20: Obstruction test setup

1. Setup the measurement system following the user manual included with the measurement tool.
2. Apply power and/or pressure to the system.



CAUTION!

Be aware the system could move when applying power and/or pressure to the system.

3. Put the doors in open position.
4. Execute the test according to the applicable regulations.

When the test is not successful;

- Check the safety parts of system.
- Check adjustments following the installation manual.



WARNING!

Remove the power and/or pressure from the system after executing this step and before you continue.

3.3.4 Grease bearing house

The bearing house is greased before delivery. In some cases the bearing house needs a refill.
(Use "Arcanol MULTITOP" or a grease with similar specifications)

NOTICE

If a refill is needed with grease, do not use more as 20gr. When the bearing house has too much grease, the friction will hinder a smooth opening and closing of the door system.

1. The bearing houses run silent and smoothly over the guiding shaft.
2. If there is thin grease on the guiding shaft. The grease could be refilled.

3.3.5 Grease spiral cable guiding shaft

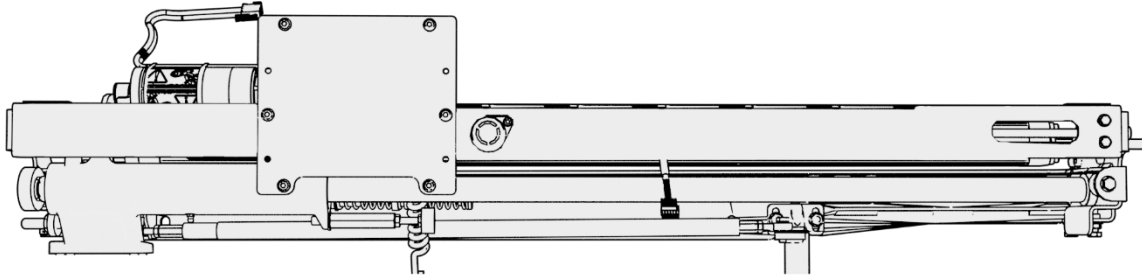

Figure 21: View of the mechanism

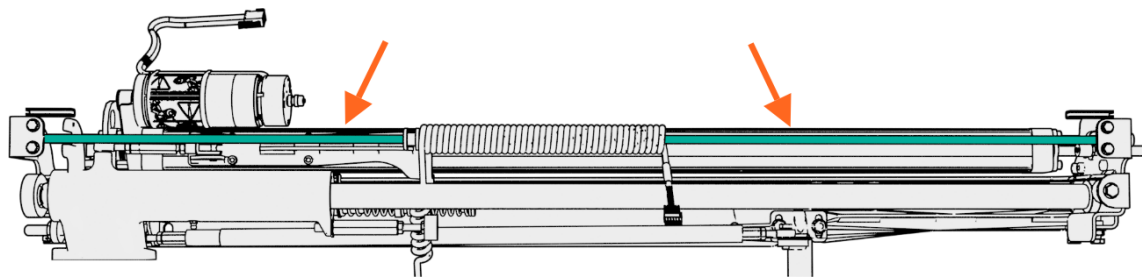

Figure 22: Spiral cable guiding shaft

The guiding shaft is directly behind the cover plate.

- Put the doors in open position.
 1. The shaft is clean of dirt.
 2. There is a layer of grease on the guiding shaft, which helps the spiral cable run smoothly over the shaft.

Apply grease when needed. (Use "Kroon Multi Purpose Lithep EP2" or a grease with similar specifications)

3.3.6 Trolley insulation parts

For the safety of the passengers the trolley rapid slide doorsystem has insulations in place to ensure no parts that can be touched by passengers are energized. Because of this it is of utmost importance that the insulating parts are not worn or damaged. Ventura is not accountable when these insulations are not properly checked and maintained. Execute the following steps for both sides of the door system.

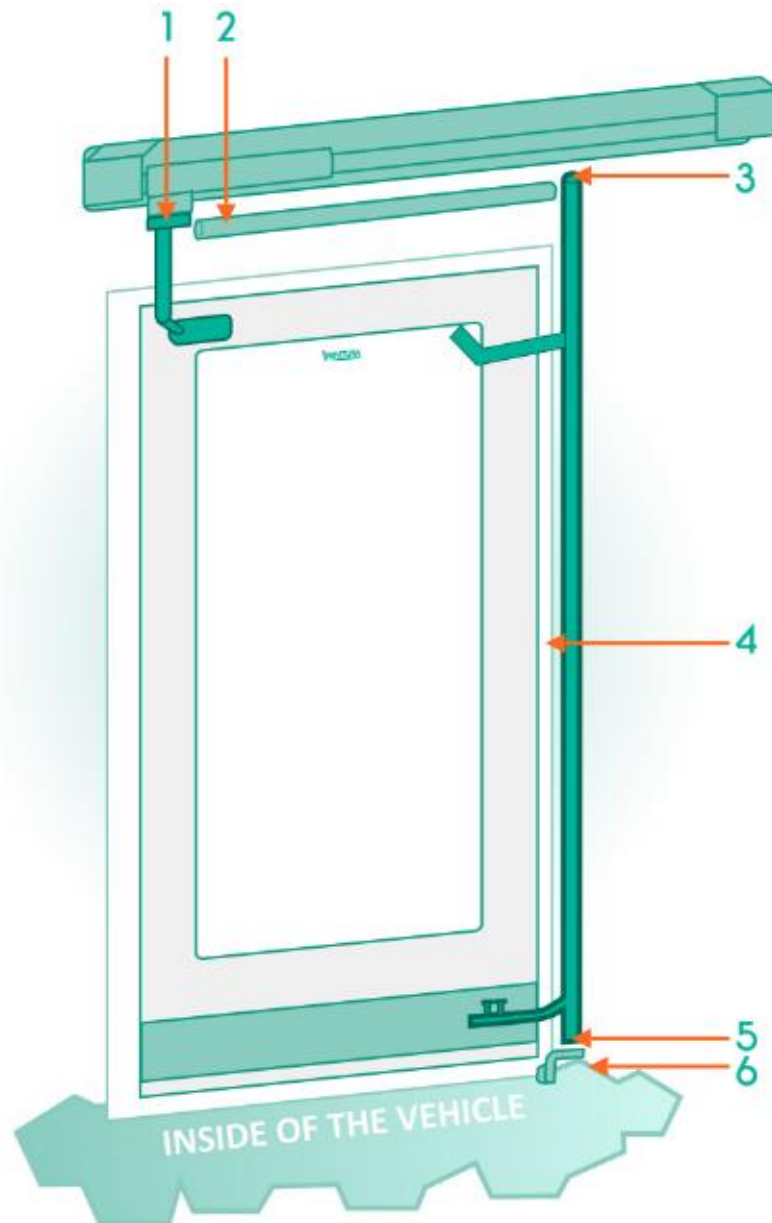

Figure 23: Insulation parts overview.

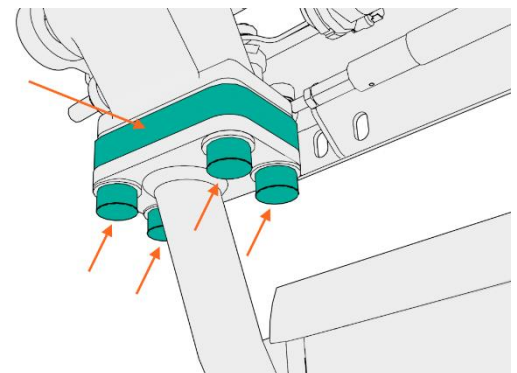

Figure 24: Doorarm insulation

Position 1

Check if

- The insulation between the doorarm and the bearinghouse is not worn or damaged.
- The insulation on the bolts are not worn or damaged and make sure there is no contact between the metal of the doorarm and the bolts.

Position 2

Check if

- The insulation is not worn or damaged and there is no contact between metals.

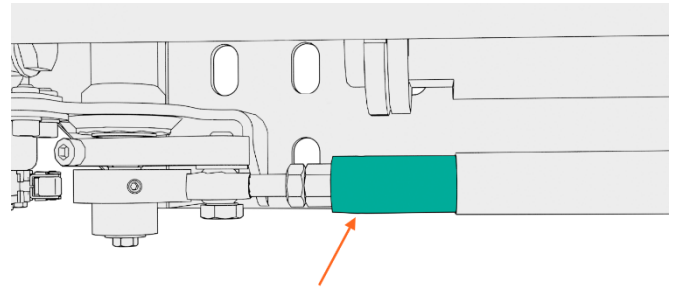

Figure 25: Connection rod insulation

Position 3

Check if

- The bearing bush is not worn or damaged.

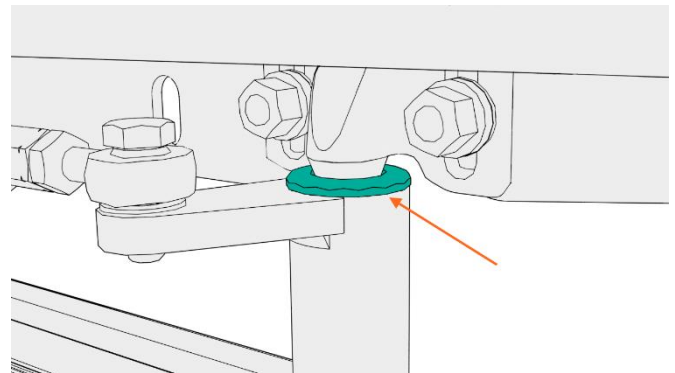

Figure 26: Top doorshaft insulation

Position 4

The lock insulation is located inside the portal rubber. Check if

- The lock insulation is not worn or damaged.
- The lock insulation catches the lock pin correctly when locking the door.

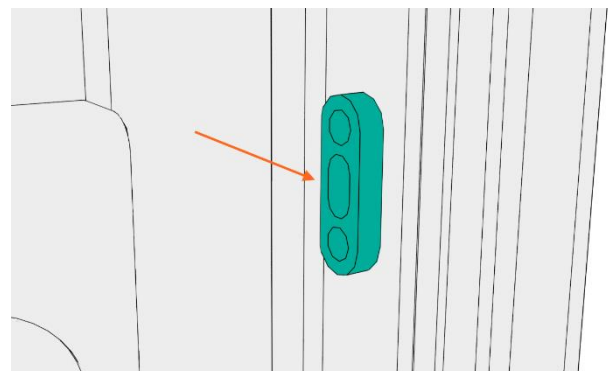

Figure 27: Lock insulation

Position 5

Check if

- The bearing bush is not worn or damaged.

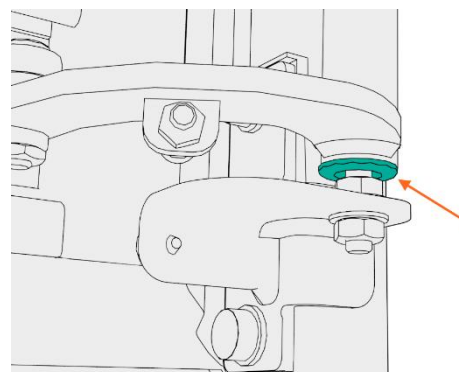

Figure 28: Bottom doorshaft insulation

Position 6

Check if

- The insulation between the bottom support and the portal is not worn or damaged.
- The insulation on the bolts are not worn or damaged and make sure there is no contact between the metal of the portal and the bolts.

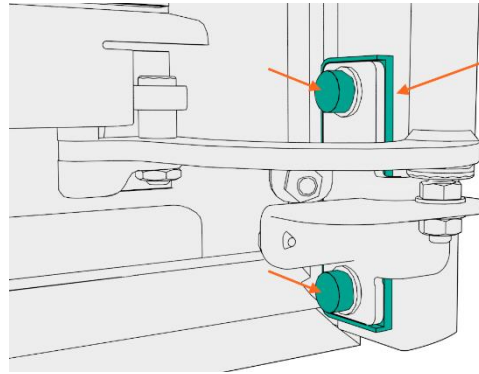

Figure 29: Bottom support insulation

4 Torque Settings

All generic rapid slide settings that require torque tightening are in this chapter. Check if all mentioned fasteners are on the correct torque settings. The torque settings of marked fasteners may be verified by checking if the marking is intact. The fasteners which connect Ventura parts onto the vehicle are, in most cases, non-Ventura parts. Therefore the torque of these fasteners is not defined by Ventura.

After setting a part to torque specification, mark the connection with a torque marker.

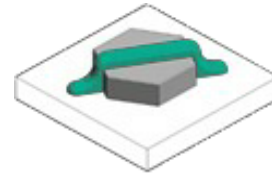

Figure 30: mark the fasteners with a torque marker.

The position in the system overview have details in the following part of this manual. In the second part the torque settings are described.

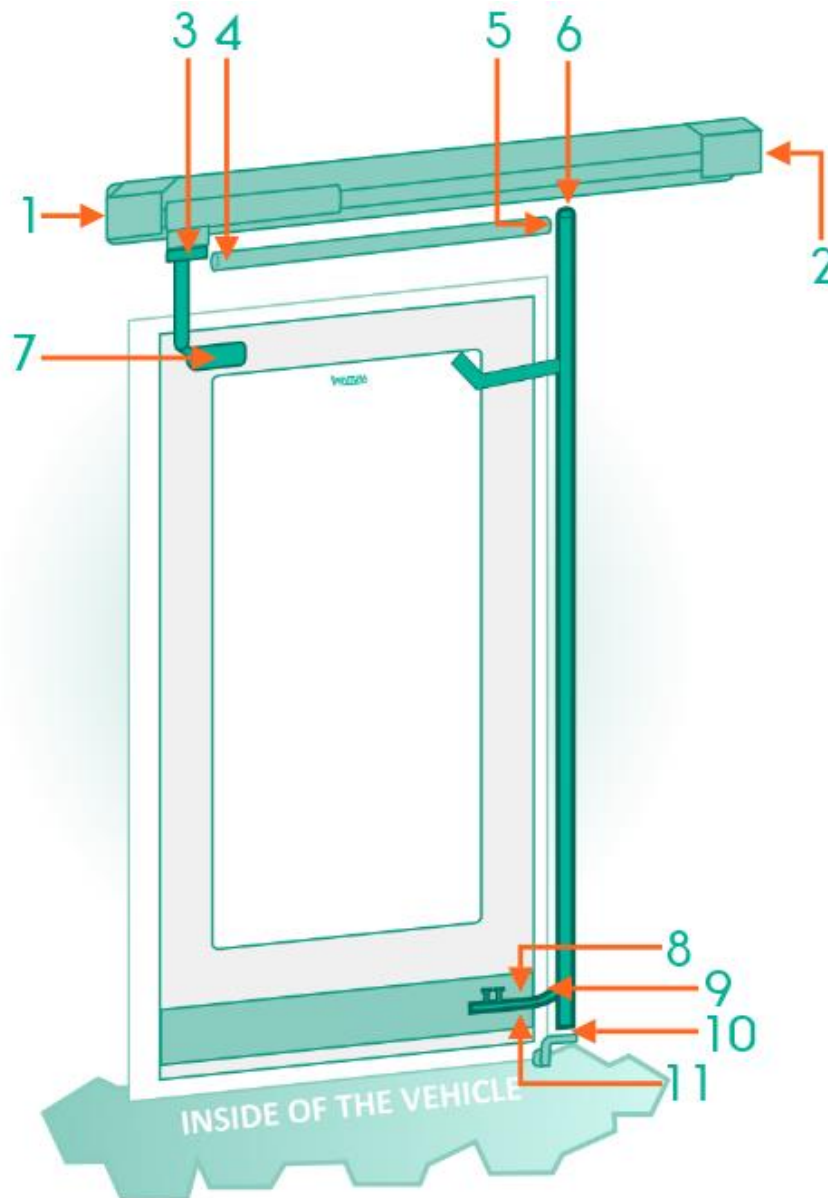
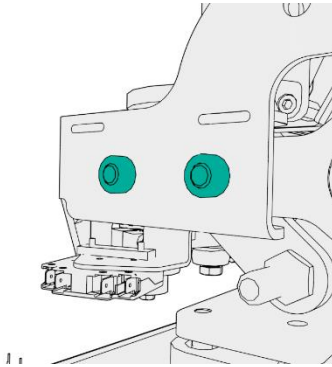

Figure 31: torque setting overview.

Position 1



45±4 Nm, 2pc

Position 2

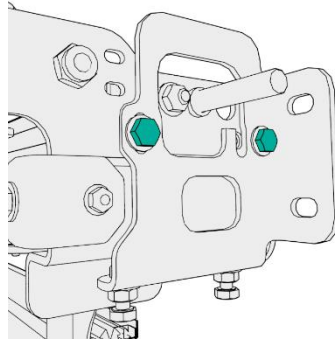

22±2 Nm, 2pc

Position 3

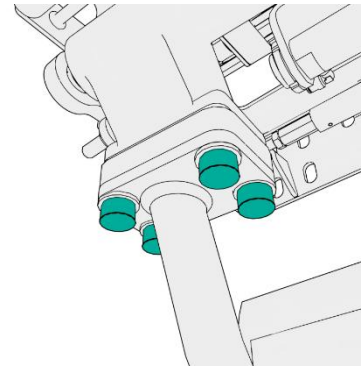

Loctite 243 on the bolt.
30 -2 +0 Nm, 4 pc

Position 4

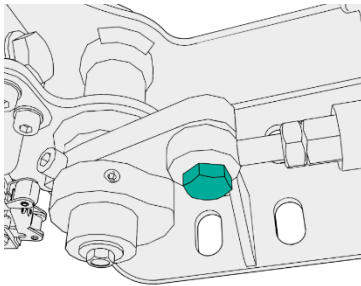

22±2 Nm

Position 5

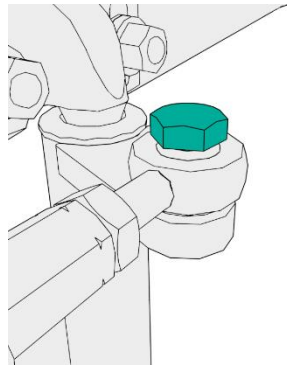

22±2 Nm

Position 5

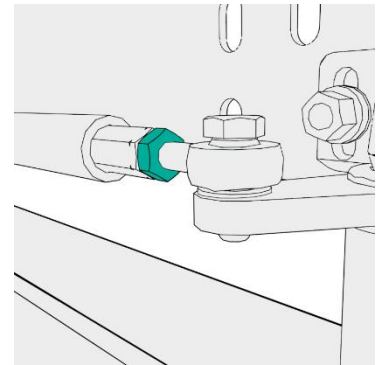

13±1 Nm

Position 6

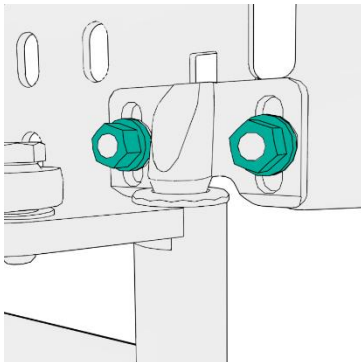

13±1 Nm, 2pc

Position 7

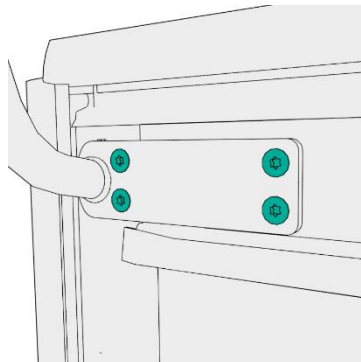

Loctite 243 on the bolt.
59±5 Nm, 4-6pc

Position 8

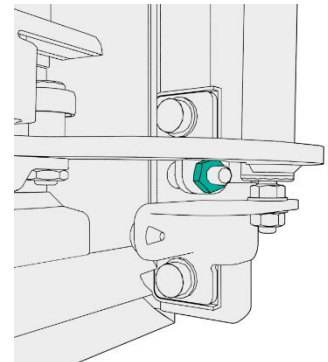

22±2 Nm

Position 9

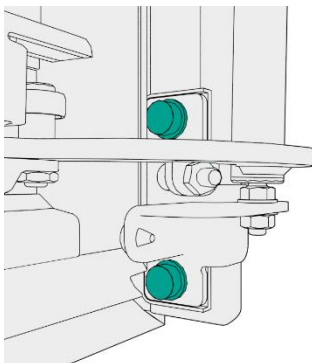

Loctite 243 on the bolt.
15±2 Nm

Position 10

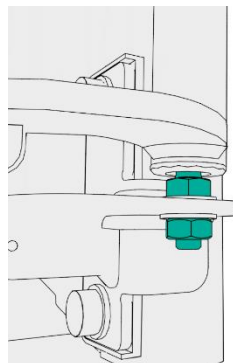

45±4 Nm

Position 10

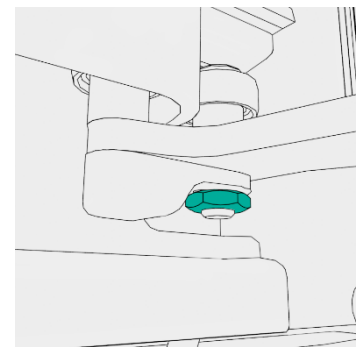

Loctite 243 on the bolt.
8±1 Nm

5 Operational checks

Execute these checks before applying power.



WARNING!

Applying power to an unchecked system may result in a potentially hazardous situation which, if not avoided, could result in death or serious injury.

No.	Check	Verified by	Approved
1.	Be assured all fasteners are on torque as described in the installation manual of this system.		
2.	Check if no cables/tubes are loose on the system.		
3.	Check if all parts are in place.		
4.	Manually check if the door leaf/leaves open and close without obstructions.		
5.	All safety parts are connected.		

After these checks, the power may be applied.

5.1 Operation and controls

These checks are all with power and/or pressure.

No.	Check	Verified by	Approved
1.	In case of Pneumatic parts: There is no leakage in the pneumatic system. Also, no leakage while opening and closing the doors.		
2.	In case of electric parts: Check if the electric parts and wires has no short circuits or damages.		
3.	Check if all settings match the installation manual.		

5.2 Safety checks

These checks are all with power and/or pressure.

No.	Check	Verified by	Approved
1.	All emergency buttons are functioning.		
2.	Check pneumatic obstruction detections. (if applicable)		
3.	Apply an obstruction while closing. Doors open again. test left and right separately. *CAUTION!		
4.	Apply an obstruction while opening. Doors go to half open position. Test left and right separately. (if applicable) *CAUTION!		
5.	Check if the mechanism goes overcenter in closed position.		
6.	In case of a Trolley doorsystem, check if the insulations are not worn nor damaged.		



CAUTION!

Do not use body parts to apply an obstruction.

6 Contact

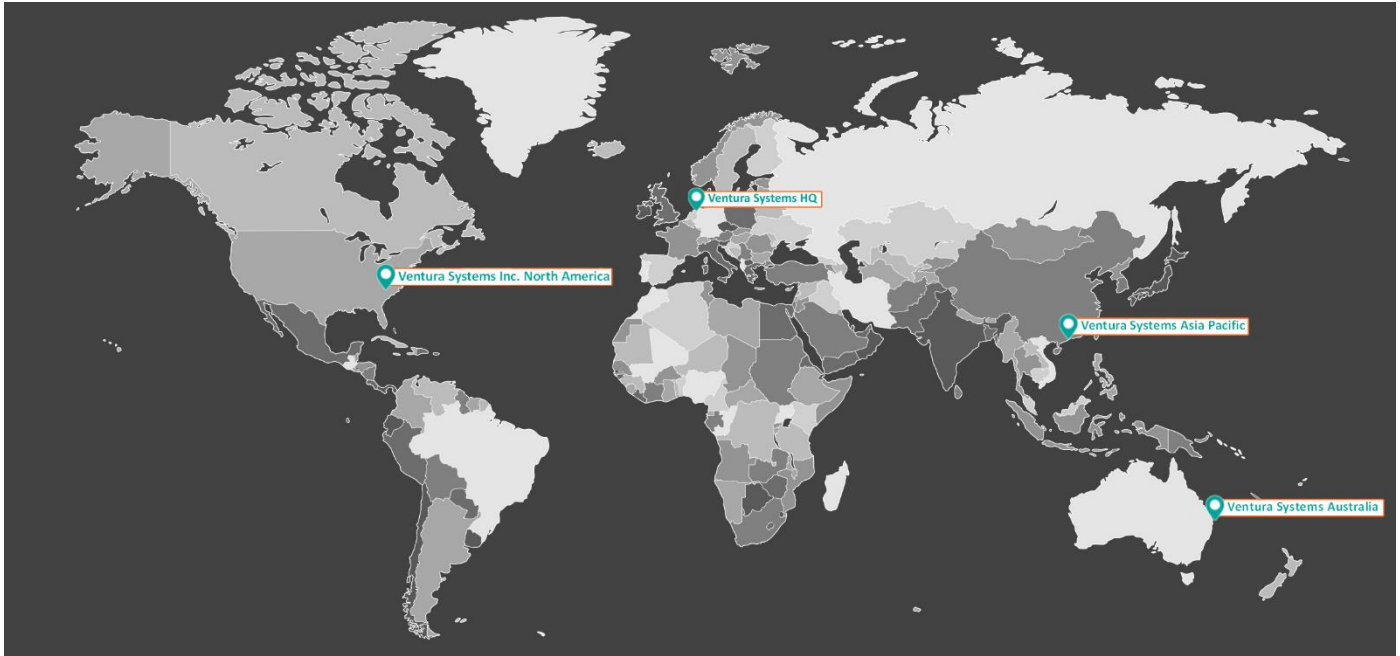

Figure 32: World map Ventura locations

Ventura Systems HQ	Ventura Systems Asia Pacific	Ventura Systems Australia	Ventura Systems Inc North America
 De Marne 216 8701MH Bolsward The Netherlands	Unit 10 on the 13/F Fotan Industrial Centre 26-28 Au Pui Wan Street Hong Kong	PO Box 284 Sanctuary Cove QLD 4212 Australia	160 Gibson Ct NC 28034 Dallas
 +31 (0) 51 557 7750	+852 2712 6001		+1 704-691-0311
 +31 (0) 51 557 3410	+852 2512 2325		+1 704-691-0313
 support@venturasystems.com	info@venturasystems.hk	info@venturasystems.com.au	info@venturasystems.com
 www.venturasystems.com			

Table 5: General contact information



Ventura Systems HQ	Ventura Systems Asia Pacific	Ventura Systems Australia	Ventura Systems Inc North America
 parts@venturasystems.com	info@venturasystems.hk	info@venturasystems.com.au	info@venturasystems.com
 +31 (0) 515 577485			

Table 6: Parts contact information

Contact your local Agent for parts.