



Service instruction: SM013E
Revision: 1
Date: 05-01-2011
Page no.: 1

Title: Guide roller securing retrofit

1. Purpose:

This work instruction describes how to determine whether a retrofit of the guide roller securing is necessary and how to execute the retrofit.

Revision no.	Date:		
1	05-01-2011	Description of the change:	First release
		Name & function:	Remco Versteeg Service Manager

Title: Guide roller securing retrofit

2. References:

- 2.1. ISO 9001 (2008) §7.5.1 Control of production and service provision

3. Definitions:

- 3.1. None

4. Forms:

- 4.1. None

5. Scope:

- 5.1. This work instruction is applicable for double-leaf plug sliding doors.

6. Problem:

- 6.1. Door leaf may detach from the guide roller on the door shaft, due to an external force on the door leaf from the inside of the vehicle.

7. Cause:

- 7.1. Door leaf set incorrectly.

8. Urgency

- 8.1. High: Action required immediately.

9. Tools / Material:

- | | <i>Quantity</i> | <i>Description</i> | <i>P/N</i> |
|------|-----------------|--|------------|
| 9.1. | as req. | Guide roller securing retrofit kit (per door leaf) | M801 |

10. Execution:

- 10.1. Check which door type is fitted.
- 10.1.1. All Plug Sliding doors are affected by this Service Instruction. Please note that doors from different manufacturers may be fitted on the same vehicle
- 10.1.2. **No** check is necessary on doorway 1, as these doors are from a different type.
- 10.2. The following work must be performed on Plug Sliding doors from Ventura:
- 10.2.1. Check the setting dimension between the door rail and the lower arm of the door shaft when the door is closed; if necessary; adjust the height of the door shaft. Each door shaft must be checked and, if necessary, adjusted individually.
- 10.2.2. In some rare cases, it may happen that the setting dimension in accordance with the description on § 10.4 cannot be achieved by adjusting the door shaft. In that case please get in contact with Ventura Systems.
- 10.2.3. Fit the "guide roller securing retrofit kit". One retrofit kit M801 is required for every door leaf. This part also avoids that changes in the set up afterwards can lead to tolerances from more than 8 mm.

Title: Guide roller securing retrofit

10.2.4. Please check if there is a fork welded in the door rail as shown on § 10.6. In that case it is not necessary to mount the retrofit kit.

10.3. Checking the setting dimensions between the door rail and the lower arm of the door shaft.

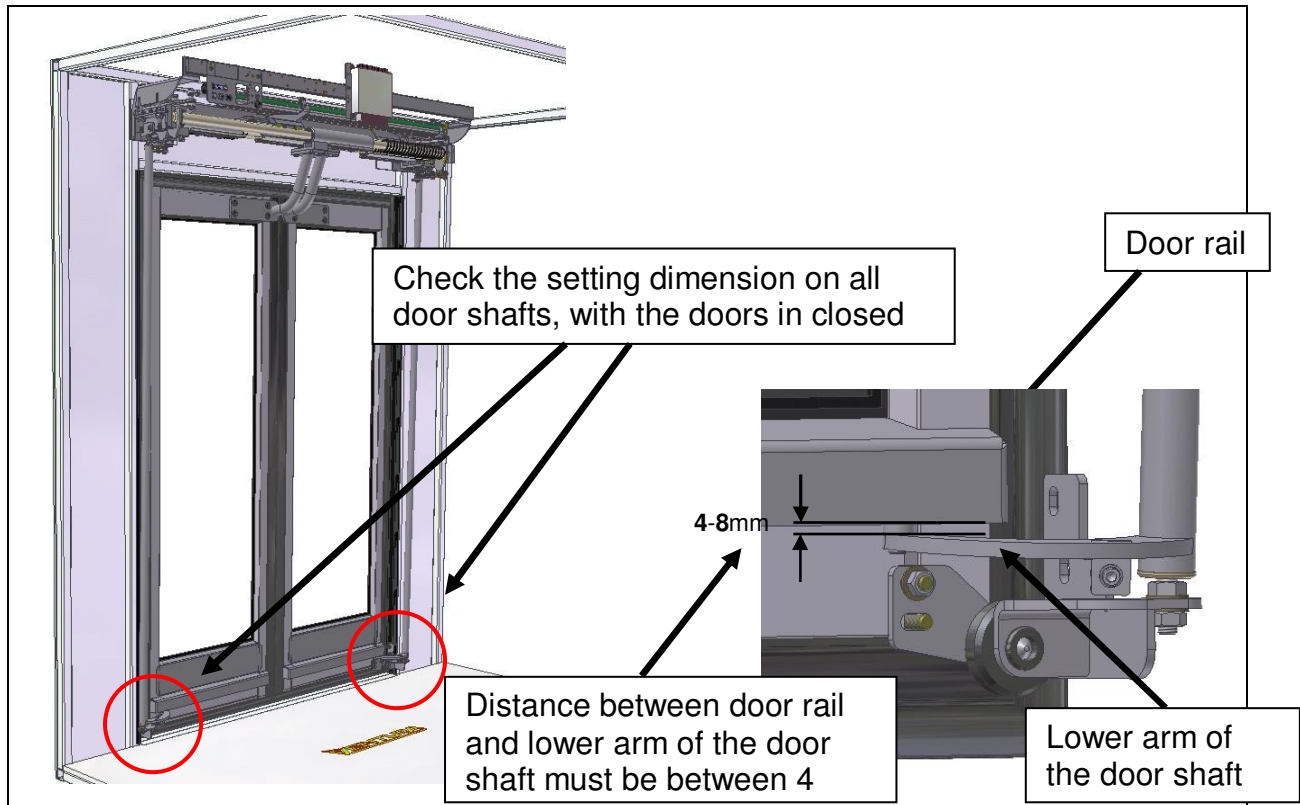

- A door leaf with a setting dimension of 4 mm to 8 mm is OK; in this case, continue with the work steps on § 10.5.
- In the event of door leaves with a setting dimension less than 4 mm or more than 8 mm, the height of the door shaft must be adjusted; in this case, continue with the work steps on § 10.4, and then perform the work steps on § 10.5.

10.4. Checking the setting dimensions between the door rail and the lower arm of the door shaft.

10.4.1. The door shafts can be adjusted independently.

10.4.2. In order to modify the dimension between the door rail and the lower arm of the door shaft, the door shaft must be shifted upwards or downwards.

10.4.3. Work steps:

10.4.3.1. Depressurize the door control system using the emergency release.

10.4.3.2. Close the doors by hand until the rubber door seals touch.

Title: Guide roller securing retrofit

- 10.4.3.3. Successively loosen the upper and lower mounting bolts of the door shaft.
- 10.4.3.4. Adjust the dimension between the door rail and the lower arm of the door shaft to between 4 mm and 8 mm by shifting the door shaft upwards or downwards along the slots. Then tighten the mounting bolts of the door shaft. Tightening torque: 20 Nm.
- 10.4.3.5. In some rare cases, it may happen that the setting dimension (4 mm to 8 mm) is not achieved by adjusting the door shaft. In these cases contact Ventura Systems.

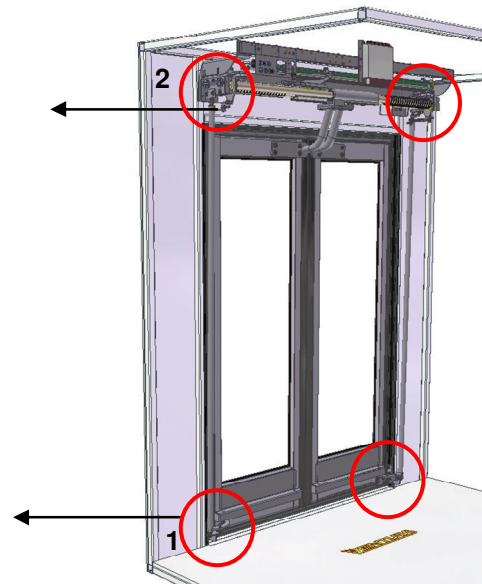
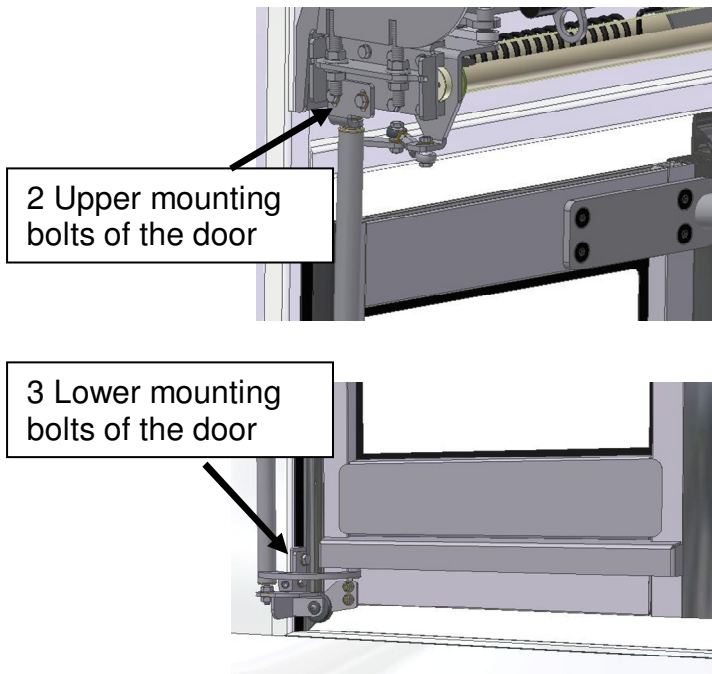

- 10.4.3.6. Check if the catch pins or catch wedges are positioned correctly. If necessary adjust the catch pins or catch wedges. There are two different versions as shown below.

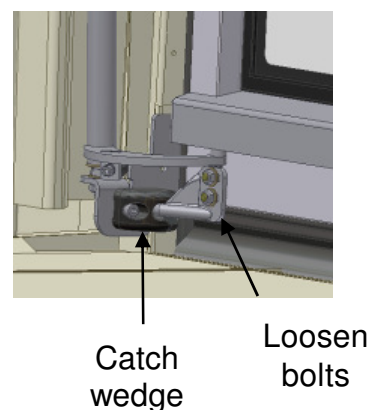
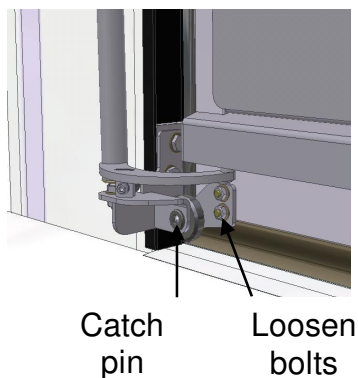

Title: Guide roller securing retrofit

10.5. Fitting the guide roller securing retrofit kit M801

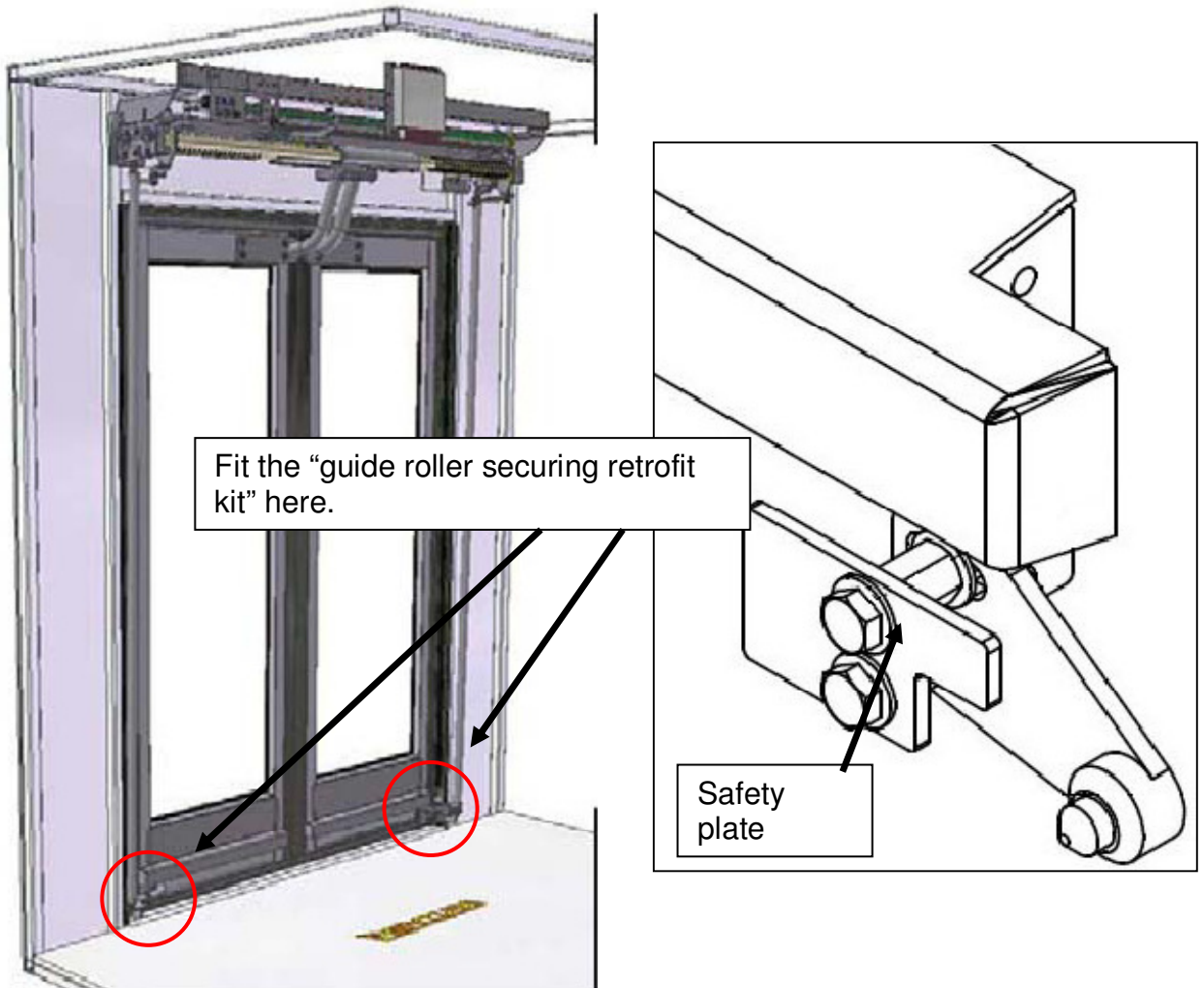

10.5.1. Work steps:

- 10.5.1.1. Pressurize the door control system using the reset function of the emergency device.
- 10.5.1.2. Close the doors.
- 10.5.1.3. Mount the "**Guide roller securing retrofit kit**" with a torque of 20 Nm

Title: Guide roller securing retrofit

10.6. New development for door leaves supplied from March 2010

- 10.6.1. From March 2010 Ventura introduced a series change in the production of Plug Sliding doors.
- 10.6.2. At the end of the bottom rail where the door shaft is guided, there is a fork welded in to the rail.
- 10.6.3. This is to avoid the door leaf coming loose from the door shaft when there is an external force on the door leaf from the inside of the vehicle.



Welded fork to avoid the roller to come out of the rail.

