

MM

Plug Sliding Door System 2 Electric

Maintenance Manual

Version	4.1
Release date	2026-06-24
Document ID	PS2200001
Project name	Plug Sliding Door System 2
Project ID	PS2

we welcome millions of people every day



Revision history

Revision	Date	By	Description
4.1	2026-06-24	Prepared: <i>O. Post</i> Verified: <i>M. Rewti</i>	<ul style="list-style-type: none"> - Modified a few texts and images - Added 'Required documentation' - Updated sensitive edge - Updated the Operational Checks chapter - Added maintenance checklist
4.0	2025-02-27	Prepared: <i>O. Post</i> Verified: <i>M. Rewti</i>	<p>(The mentioned revisions are with respect to the former general maintenance manual)</p> <ul style="list-style-type: none"> - First issue of the PS2 maintenance manual only for electrically driven door systems. For pneumatically driven systems, a separate manual has been issued. - Removed specifically pneumatic topics - Small spelling and grammar improvements - Restyling of images - Updated in 'Maintenance' the introductory text and the maintenance frequencies - Updated 'Sensitive edge' - Added flexible coupler - Removed 'Clamping force test' - Updated 'Operational checks' - Shifted 'Air leakage test' to the appendix section
3.2	2024-02-12	Prepared: <i>O. Post</i> Verified: <i>M. Rewti</i>	<p>General:</p> <ul style="list-style-type: none"> - Minor changes and/or updates in spelling, grammar, lay-out. - A number of images were restyled. <p>Chapter Introduction:</p> <ul style="list-style-type: none"> - Updated 'References'. <p>Chapter Maintenance:</p> <ul style="list-style-type: none"> - Updated 'Emergency release' (added image). - Updated 'Micro switches'. - Updated 'Over center soft stopper'. <p>Chapter Torque settings:</p> <ul style="list-style-type: none"> - Removed position 5 the tension bracket, because it is preset. <p>Appendix A:</p> <ul style="list-style-type: none"> - Updated e-mail addresses
3.1	2022-05-09	Prepared: <i>M. Stoelinga</i>	<ul style="list-style-type: none"> Updated references. Updated overview.
3.0	2021-12-20	Prepared: <i>M. Stoelinga</i>	<ul style="list-style-type: none"> Adjusted preface. Adjusted references. Added notice to apply commissioning settings. Minor text improvements. Added chapter Pneumatic potentiometer tension bracket. Updated overcenter soft stopper. Added torque position 13.
2.1	2021-03-26	Prepared: <i>M. Stoelinga</i>	<ul style="list-style-type: none"> Torque setting can be checked by checking the torque marking.
2.0	2021-03-19	Prepared: <i>M. Stoelinga</i>	<ul style="list-style-type: none"> Adjusted Torque Setting coupler.
1.2	2020-12-21	Prepared: <i>M. Stoelinga</i>	<ul style="list-style-type: none"> Minor text changes Adjusted Torque Setting catch wedge Clarify chapter "Grease bearing house"
1.1	2020-05-20	Prepared: <i>M. Stoelinga</i>	<ul style="list-style-type: none"> Replaced Manual with Document. Adjusted references. Added repair option to sensitive edge chapter. Added Torque settings chapter
1.0	2019-07-19	Prepared: <i>M. Stoelinga</i>	<ul style="list-style-type: none"> Chapter microswitches updated. Added reference.



			Update Acronyms and Abbreviations. Minor textual and lay-out changes.
0.6	2018-12-20	Prepared: <i>M.Stoelinga</i>	Minor lay-out changes. Removed 10.000 cycle reference.
0.5	2018-12-04	Prepared: <i>M.Stoelinga</i>	Frequency changed. Moved "Clamping force test" from "Safety parts" to "Part inspections". Added the sentence: "Contact your local Agent for parts." Adjusted filter regulator check for electric systems with non-Ventura DCU.
0.4	2018-11-15	Prepared: <i>M.Stoelinga</i>	Rephrased safety checks. Added "Only applicable for electric systems" to spindle nut. Changed reference from appendix to installation manual. Adjusted contact information.
0.3	2018-11-13	Prepared: <i>M.Stoelinga</i>	Adjusted emergency release. Removed step 3. Added contact page. Added simple check, sensitive edge procedure. Small changes to introduction for safety parts and wear parts.
0.2	2018-11-02	Prepared: <i>M.Stoelinga</i>	Maintenance frequencies changed.
0.1	2018-10-10	Prepared: <i>M.Stoelinga</i> <i>M.Delorme</i>	Initial version.



Preface

The Quality System of Ventura Systems is certified to IATF 16949:2016 and ISO 14001:2015.

All rights reserved. Disclosure to third parties of this document or any part thereof, or the use of any information contained therein for purposes other than provided for by this document, is not permitted, except with prior and express written permission from Ventura Systems.

Printed documents are uncontrolled. Documents are subject to change therefore verify correct revision before use.



Table of Contents

1 Introduction.....	7
1.1 Purpose.....	7
1.2 Scope	7
1.3 Definitions	7
1.4 Acronyms and abbreviations.....	7
1.5 References.....	7
1.5.1 External documents.....	7
1.5.2 Quality manual documents	7
1.5.3 Project documents.....	7
1.6 Required documentation.....	8
1.7 Required tools.....	8
1.8 Maintenance checklists	8
1.9 Overview.....	8
2 Safety of the door system.....	9
2.1 General.....	9
2.2 Disclaimer	9
2.3 Safety alert symbols.....	10
2.4 Safety instructions	11
3 Maintenance.....	12
3.1 Safety parts.....	13
3.1.1 Lever block	13
3.1.2 Emergency release.....	13
3.1.3 Sensitive edge	14
3.1.4 Closed switch	16
3.2 Wear parts.....	18
3.2.1 Spindle nut	18
3.2.2 Spindle's flexible coupler	18
3.2.3 Over center soft stopper	19
3.2.4 Cushioning rubber bearing house.....	19
3.2.5 Guide rollers.....	20
3.2.6 Bottom stopper.....	20
3.2.7 Catch block and door wedge.....	20
3.3 Parts inspections	21
3.3.1 Door shafts.....	21
3.3.2 Filter regulator	21
3.3.3 Tension steel cables.....	21
3.3.4 Grease bearing house.....	22
3.3.5 Grease spiral cable guiding shaft	22
3.3.6 Air leakage.....	22
4 Torque Settings.....	23
5 Operational checks.....	26
5.1 General checks before power	26
5.2 Operation and controls.....	26
5.3 Safety checks.....	26
Appendix A - Contact.....	27
Appendix B - Air leakage test	28
Appendix C - Maintenance checklist	30

List of Figures

Figure 1: Lever block	13
Figure 2: Dismount the door leaf (shape may vary)	14
Figure 3: Disconnect the sensitive edge connectors	14
Figure 4: Lock guide roller inside the door rail (cross section). Use Loctite.....	15
Figure 5: Closed switch and over center lever, top view	16
Figure 6: Over center soft stopper, side view	16
Figure 7: Adjustment tool VB8538	16
Figure 8: Closed switch	16
Figure 9: Position the 6 mm adjustment tool	16
Figure 10: Adjusting cam position	17
Figure 11: Position the 8 mm adjustment tool.....	17



Figure 12: Spindle nut18

Figure 13: Flexible coupler's location. The marked part is the 'spider'.18

Figure 14: Spider of the flexible coupler18

Figure 15: Over center soft stopper, side view19

Figure 16: Over center mechanism, side view19

Figure 17: Rubber cushioning ring.....19

Figure 18: Guide roller20

Figure 19: Distance between bottom lever and guiding rail20

Figure 20: Bottom stopper.....20

Figure 21: Door wedge and catch block locations.....20

Figure 22: Check catch block20

Figure 23: Top bearing door shaft21

Figure 24: Bottom bearing door shaft21

Figure 25: Regulator21

Figure 26: Filter regulator21

Figure 27: Tension meter21

Figure 28: Grease bearing housing.....22

Figure 29: Spiral cable guiding shaft.....22

Figure 30: Torque marker23

Figure 31: Torque setting overview.....23

Figure 32: World map Ventura locations27

Figure 33: Legend for air leakage images.....28

Figure 34: Testing complete door system.....28

Figure 35: Testing door open position29

Figure 36: Testing door closed position29

List of Tables

Table 1: Definitions.....7

Table 2: Acronyms and abbreviations7

Table 3: External documents7

Table 4: Quality manual documents.....7

Table 5: Project documents7

Table 6: Assembling and adjustment tools8

Table 7: Maintenance frequencies12

Table 8: General contact and parts information HQ and Asia Pacific27

Table 9: General contact and parts information Australia and North America27

Table 10: Air leakage values.....28



1 Introduction

1.1 Purpose

This maintenance manual is provided to guide trained service mechanics through the maintenance steps of the Ventura door system.

1.2 Scope

This manual is intended for the Ventura electrically driven plug slide door system PS2.

1.3 Definitions

Definition	Description
Wear part	Wear is progressive damage to a part caused by movement in contact with another substance or part.
Safety part	A safety part is a part, which is important to the overall safety of a system.

Table 1: Definitions

1.4 Acronyms and abbreviations

Abbreviation	Description
DCU	Door Control Unit
HQ	Headquarters
IATF	International Automotive Task Force
ISO	International Standardization Organization
PS	Plug Sliding door system

Table 2: Acronyms and abbreviations

1.5 References

1.5.1 External documents

#	Reference	Description	Date
1	IATF 16949:2016	Automotive quality management system standard	2016-10-01
2	ISO 14001:2015	Environmental management systems – Requirements with guidance for use	2015-10-01
3	ISO 9001:2015	ISO Standard for Quality Management Systems – Requirements.	2015-10-01

Table 3: External documents

1.5.2 Quality manual documents

#	Reference	Type	Description	Revision	Date
1	QM000001	DG	Documentation Guideline	6.0	2024-04-18

Table 4: Quality manual documents

1.5.3 Project documents

#	Reference	Type	Description	Revision	Date
1	PS2200002	IM	Plug Sliding Door System 2 : Installation Manual	7.0	2026-04-20
2	PS2200006	CM	PS2 Electric Ventura DCU : Commissioning Manual	2.1	2024-07-17

Table 5: Project documents



1.6 Required documentation

- Installation manual
- Door system drawing
- Commissioning manual

1.7 Required tools

To prevent damage to the door system and personal injury, it is important to use calibrated tools of good quality. The tools listed below are used when assembling and adjusting the Ventura door systems.

Note that all tools are metric.

Tool	Dimensions
Wrench / socket wrench / combination ratchet wrench (metric)	Complete set (6 - 24 mm)
Allen key (metric)	5 mm
Torx key (metric)	Set T10-T50
Torque wrench	*
Screw driver PH2	-
Side cutters	-
Utility knife	-
Vernier caliper / tape measure / laser distance meter / drawing hook	-
Loctite 243	-

Table 6: Assembling and adjustment tools

* For the required range, see the torque pages in this manual.

1.8 Maintenance checklists

As an appendix, a maintenance checklist has been provided. If desired, it can be printed and serve as sign-off document.

1.9 Overview

The list below shows a brief overview of the contents of each chapter:

1. Gives an introduction, definitions and overview of this document.
2. Contains the general door system safety instructions, safety symbols and disclaimer.
3. Contains the maintenance instructions.
4. Contains the torque settings.
5. Contains operational checks before and after applying power.

App.A Contains contact information.

App.B Contains an air leakage test.

App.C Contains the maintenance checklist.



2 Safety of the door system

2.1 General

Safety of the operator and bystanders is one of the main concerns in designing and developing a new piece of equipment. Ventura's door systems have the proper safety features for common use of the system. An accident can often be avoided by recognizing potentially hazardous situations before an accident occurs. As you install, operate, or maintain the door system, you must be alert to potential hazards. Make sure you have the necessary training, skills and tools to perform any assembly, or maintenance procedures. Improper operation and maintenance of this door system may result in a dangerous situation that may cause injury or death.

Ventura Systems cannot anticipate every possible circumstance that may involve a potential hazard. The warnings in this document and on the product are not all-inclusive. If a method of installation or operation is used, which is not specifically recommended by Ventura Systems, you must satisfy yourself that it is safe for you and for others. You should also ensure that the door system will not be damaged or be made unsafe by the installation and/or operational methods you choose. The information, specifications and illustrations in this document are based on the information that was available at the time this document was written and can change at any time without notice.

2.2 Disclaimer

The information contained in this maintenance document is based upon reliable technical data at the time the document was published. These instructions are intended for use by persons having the technical knowledge to maintain this door system. The instructions are to be used at the maintenance mechanic's own discretion and risk. Ventura Systems assumes no responsibility for results obtained or damage incurred from the use of this material either in whole or in part by the installer. This document provides basic instructions for the maintenance of the door system in a step-by-step sequence that will work in most types of maintenances. While effort has been made to ensure the information in this document is correct and complete, we would appreciate it if you would contact us in case of errors.



2.3 Safety alert symbols

This document contains safety messages which alert you to potential personal injury hazards. Obey all safety messages in this document to avoid possible injury or death. The following keywords and layouts call for your attention: DANGER, WARNING, CAUTION and NOTICE. Below are examples of these safety messages. The NOTE message is used for additional information not threatening the mechanic, bystanders, nor the door system.



DANGER!

Indicates an imminently hazardous situation which, if not avoided, will result in death or serious injury. This signal word is limited to the most extreme situations.



WARNING!

Indicates a potentially hazardous situation which, if not avoided, could result in death or serious injury.



CAUTION!

Indicates a potentially hazardous situation which, if not avoided, may result in minor or moderate injury.

NOTICE

Indicates that equipment or property damage can result if instructions are not followed.

NOTE

Additional information important but not threatening to people or the system.



2.4 Safety instructions



WARNING!

This door system is designed for a specific application;

DO NOT modify or use this unit for any application other than for which it was designed.

A door system operated improperly or by untrained personnel is dangerous. Lack of operation knowledge may cause high risk.

Do not install, maintain or operate this door system if it is damaged. If you are in doubt if the door system has a defect, immediately stop your work and contact Ventura Systems.

Do not connect the door system to air or electric supply during the maintenance process. If the manual states otherwise, follow the manual.

Do not attempt to install, maintain or operate the door system under influence of drugs or alcohol.

NOTICE

Do not modify the door system or safety devices. Unauthorized modifications may impair its function and safety.

If equipment has been altered in any way from the original design, Ventura Systems does not accept any liability for injury or warranty.

If replacement of parts is necessary, genuine factory replacement parts must be used to restore the door system to its original specifications.

*Always disconnect the air and electric power while replacing parts. Safety features may not be active while replacing parts.

Ventura Systems will not accept responsibility for damages as a result of the use of unapproved parts.

While working on the Ventura door systems wear appropriate personal protective equipment.

This list may include but is not limited to:

- Protective shoes with slip resistant soles
- Protective goggles, glasses or face shield
- A hard hat

Follow the regional and country laws and safety precautions.



3 Maintenance

Maintenance refers to the periodic check of wear parts and system settings. For the sake of completeness, this manual also covers the operational check of safety components, which is not actually maintenance, but could also lead to the need for repair or replacement.

Maintenance of a door system should be performed with the vehicle positioned on a flat surface, to prevent distortion/twisting of the vehicle body, which can lead to inaccurate measurements of the portal.

The table below shows the maintenance frequencies recommended by Ventura Systems. Whenever the amount of cycles is past, we advise to execute the applicable maintenance.

Cycles assumption	Minimal maintenance	Applicable for
300.000	Every 12 months	Wear parts
300.000	Every 12 months	Parts inspections

Table 7: Maintenance frequencies

Execute at least the minimal maintenance intervals.

NOTICE

After maintenance has been completed, the settings must be applied as described in the commissioning manual that came with this door system.

3.1 Safety parts

The checks in this chapter are safety critical. The safety parts are not in the regular schedule of *maintenance frequencies*, because it is recommended by Ventura Systems to check these parts before the first shift each day that the vehicle is operational. When the system has two door leaves, the checks must be executed for both sides.

If a fault is detected, it is necessary to reset, repair or replace the affected component until the defect is resolved.

3.1.1 Lever block



WARNING!

When the lever block is not in place, the door leaf could get off the guide roller when twisted, leading to situations with a high risk of injury to persons.

It is very important that the guide roller is locked in place by means of the lever block.

1. Check if the lever block is present at the bottom of the lever.
2. Check if the lever block is in the right position. It has to be inside the rail of the door leaf.
3. Measure the thickness of the block.

NOTE

If retention plates are applied, the lever block is not needed.

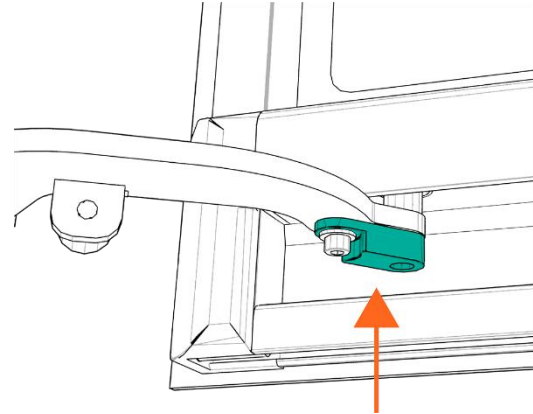

Figure 1: Lever block

3.1.2 Emergency release

If the door system is equipped with an emergency release, execute the following check.

Apply power and pressure to the system and put the door(s) in closed position.



CAUTION!

Be aware the system could move when applying power and pressure to it.

When the system is active, activate the emergency release.

The following events should occur.

1. The power/pressure is released from the system.
2. The door(s) can be opened manually.
3. Reset the emergency release.
4. Open and close the door(s) using the power source.

3.1.3 Sensitive edge



CAUTION!

Be aware the system could move each time that power and pressure are applied to it.

Consecutively do the next two tests while the doors are closing with power/air

- Pinch the right mid seal at a height of 1 meter or less. The door's movement is interrupted and the doors open.
- Pinch the left mid seal at a height of 1 meter or less. The door's movement is interrupted and the doors open.

If one or both door leaves do not open when pressing the mid seals as described, perform the following checks.

Diagnostic steps.

Measure the resistance of the sensitive edge

- Use diagnostic tooling, for example V-diaq (software by Ventura).
- Read out the resistance value of the sensitive edges.

The values should read:

	Sensitive edge with finite resistance	Sensitive edge without resistor
Not activated:	<ul style="list-style-type: none"> • $R = 4100 \Omega$ (or in very rare occasions 2400Ω) 	<ul style="list-style-type: none"> • "Error" (infinite resistance $R = \infty$)
Activated:	<ul style="list-style-type: none"> • $R \approx 0 \Omega$ (approximately zero) 	<ul style="list-style-type: none"> • $R \approx 0 \Omega$ (approximately zero)

If the values do not comply, do the following:

- Check the wiring and connectors that can be reached without disassembly of the doors.
- If the wiring or connections are defective, repair or replace them.
- Again read out the resistance values using diagnostic tooling.

If one or both values still do not comply, the corresponding door(s) will have to be disassembled.

Disassembly



WARNING!

Before continuing, remove the power and pressure from the system.

- Loosen the bolts which connect the door leaves to the door arms.
- Disconnect the door connectors from the spiral cables.

The door leaves could be removed completely to continue, in which case also the shaft bottom levers must be disconnected from the door leaves, by removing the lever blocks (if applicable), or a second engineer needs to hold the doors, while the checks are executed. The latter is preferred, because in the following the connections will be disconnected and reconnected.

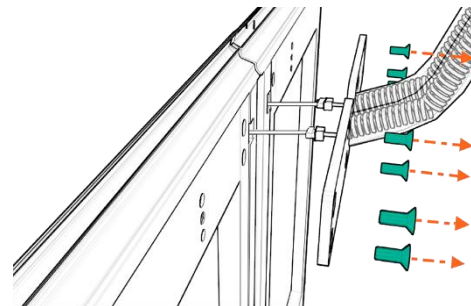

Figure 2: Dismount the door leaf (shape may vary)

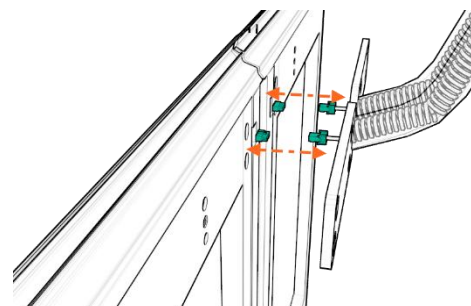

Figure 3: Disconnect the sensitive edge connectors

Diagnostics, continuation.

Measure the resistance of each door apart

- Disconnect one door connector from its spiral cable, and after reconnecting disconnect the other.

The value of each separate door should read:

	Sensitive edge with finite resistance	Sensitive edge without resistor
Not activated:	<ul style="list-style-type: none"> • $R = 8200 \Omega$ (or in very rare occasions 1200Ω) 	<ul style="list-style-type: none"> • "Error" (infinite resistance $R = \infty$)
Activated:	<ul style="list-style-type: none"> • $R \approx 0 \Omega$ (approximately zero) 	<ul style="list-style-type: none"> • $R \approx 0 \Omega$ (approximately zero)

If one value (or both) differs, this side's wiring *or* sensitive edge is defective (or both).

Measure the resistance of the wiring apart from the doors

- Now disconnect both connectors.
- The resistance measurement should read "Error".
- If it gives a finite resistance, the wiring from the spiral cable to the control must be repaired or replaced.

After repair or replacement has been done, reconnect the connector(s) and redo the previous checks.

If the wiring is good and the sensitive edge measurements still give the wrong results, the sensitive edge is probably defective. Do the following check.

Measure the sensitive edge apart from the control wiring

- Disconnect the connectors from the spiral cables.
- Connect a multimeter to the door side connector of the sensitive edge. Pins 1 and 7.

The value of each separate door should read:

	Sensitive edge with finite resistance	Sensitive edge without resistor
Not activated:	<ul style="list-style-type: none"> • $R = 8200 \Omega$ (or in very rare occasions 1200Ω) 	<ul style="list-style-type: none"> • "Error" (infinite resistance $R = \infty$)
Activated:	<ul style="list-style-type: none"> • $R \approx 0 \Omega$ (approximately zero) 	<ul style="list-style-type: none"> • $R \approx 0 \Omega$ (approximately zero)

CAUTION!

The sensitive edge is malfunctioning when, if activated, the resistance is infinite ($R = \infty$).

In case the sensitive edge turns out to be defective, it has to be replaced.

In case all checks have been approved, reinstall the door leaves and execute the calibration of the doors, as far as the door-arm-to-door-leaf connection is concerned (parallelism), following the instructions in the installation manual.

After mounting the door leaves, do place back the lever blocks (if applicable), following the relevant installation instructions.

WARNING!

The lever block has to be placed back, to lock the door leaf in place.

Put Loctite 243 on the bolt.

- Place back the block to its position on the bottom of the lever and fasten it.
- Make sure the slit is shifted over the fastener.
- Tighten the fastener to torque.

	<ul style="list-style-type: none"> • $M = 6 \pm 1 \text{ Nm}$. • Loctite 243.
---	--

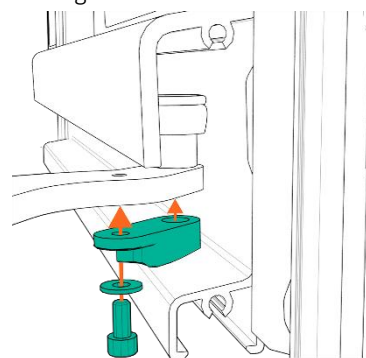

Figure 4: Lock guide roller inside the door rail (cross section).
Use Loctite.



3.1.4 Closed switch

The image to the right is a top view of the over center lever and the switch closed position ('closed switch') (1). The closed switch is located in the left part of the door mechanism and is activated/released by the over center lever (2).

When the doors close, the rod (3) is pushing the lever over center, shown by the dashed orange line making an angle with the center line.

In this process, the closed switch is activated. When the doors open again, the switch is released.

The red part (4) is the over center soft stopper.

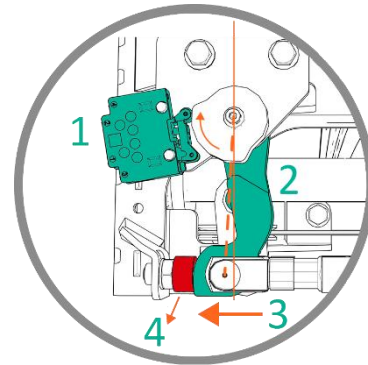

Figure 5: Closed switch and over center lever, top view

The next image gives a side view of the same position. This side view will be used in the rest of this section. The over center soft stopper is a wear part (for this, see the relevant paragraph).

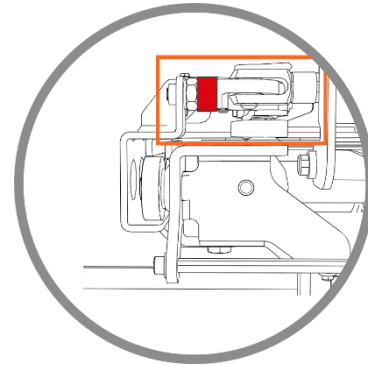

Figure 6: Over center soft stopper, side view

The closed switch needs to be checked. Adjustment could be done using the Ventura tool 6–8 mm P/N VB8538, or else a similar tool.

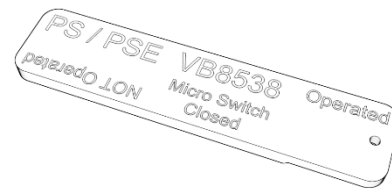

Figure 7: Adjustment tool VB8538



WARNING!

Pinch-point hazard!

The following steps have to be performed while parts of the door system are moving.

When the doors are in closed position, the closed switch (1) has to be activated. If the closed switch is not activated, follow the next steps to adjust it.

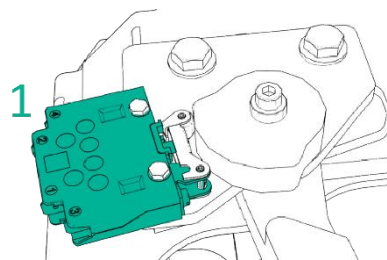

Figure 8: Closed switch

- Place the doors in an open position.
- Place the 6 mm side of the adjustment tool between the door mechanism and the end stopper (see image).
- Close the doors and move on to the next steps. Be aware of pinch point hazard.

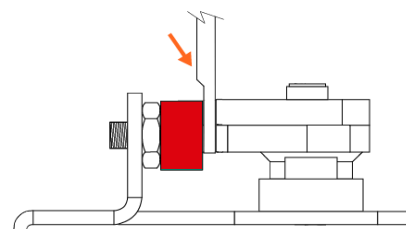

Figure 9: Position the 6 mm adjustment tool



- Unscrew the cam with an Allen key.
- Turn the cam to a position where the microswitch activates (see image).
- Fasten the cam.
- Place the doors in an open position and move on to the next steps.

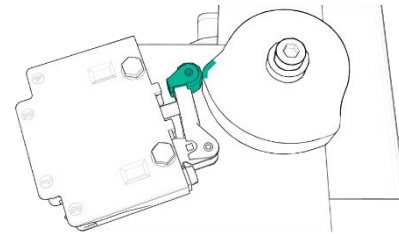

Figure 10: Adjusting cam position

- Place the 8 mm side of the adjustment tool between the door mechanism and the end stopper (see image). Be aware of pinch point hazard.
- Close the doors.
- Check if the closed switch activates. The switch should NOT be activated.
- If the switch activates, redo the previous steps.

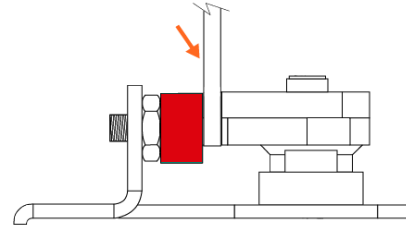

Figure 11: Position the 8 mm adjustment tool



WARNING!

Remove the power and pressure from the system after executing these steps and before continuing.

3.2 Wear parts

These parts wear out and must be replaced when damaged or worn, after the prescribed cycles or after the prescribed time the parts are in use. When a part has a maximum amount of cycles, it will be mentioned.

3.2.1 Spindle nut

1. There is no play between the spindle and spindle nut. To test this, manually twist the spindle.
2. There is no grease or dirt on the spindle, nor on the spindle nut. If there is, use a dry fabric to clean one or both.

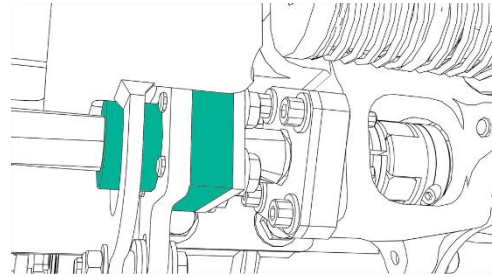

Figure 12: Spindle nut

3.2.2 Spindle's flexible coupler

1. The flexible coupler's 'spider' is not worn or damaged. Check part integrity by looking for visible cracks or damage.

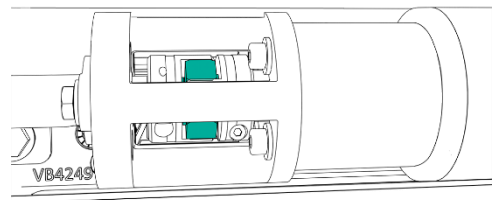

Figure 13: Flexible coupler's location. The marked part is the 'spider'.

In case replacement is necessary, dismount and then disassemble the coupler by loosening the screws, see picture. Take care that the keys are not falling out of the housing.

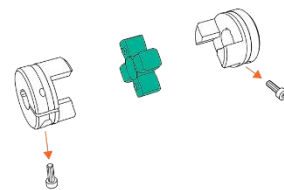

Figure 14: Spider of the flexible coupler

3.2.3 Over center soft stopper

Apply power and pressure to the system and put the doors in closed position.



CAUTION!

Be aware the system could move when applying power and pressure to it.

The over center soft stopper is located in the left part of the door mechanism, see image.

1. The lever touches the soft stopper in closed position, with power/pressure.
2. The rubber bush of the soft stopper is not worn. The inner dimension is conform the system drawing. If the bush is worn, the system will make a lot of noise at closing the doors.



WARNING!

Remove the power and pressure from the system after executing this step and before continuing.

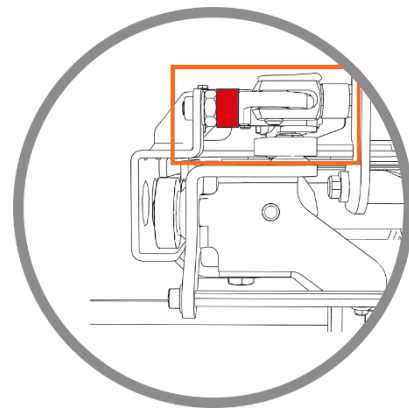

Figure 15: Over center soft stopper, side view

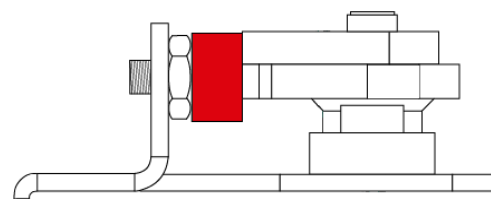

Figure 16: Over center mechanism, side view

3.2.4 Cushioning rubber bearing house

1. The cushioning rubber is present at both sides of the mechanism.
2. There is no visible damage on the cushioning rubber.

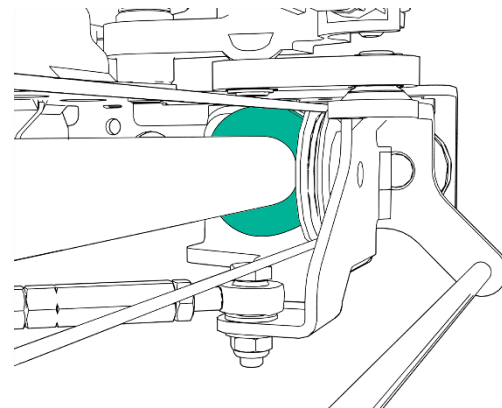

Figure 17: Rubber cushioning ring

3.2.5 Guide rollers

1. The guide rollers on the lever(s) are not worn or damaged in any way. Check for damage visually and feel if there are no flattened spots on the guide rollers. The guide rollers are located at the bottom lever.

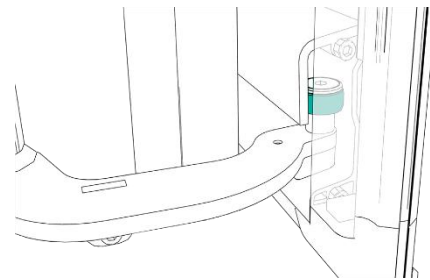

Figure 18: Guide roller

2. The clearance between the bottom lever and the guiding rail is 4-8 mm over the full length of the door movement. If it is not, adjust the height of the door shaft following the installation manual.

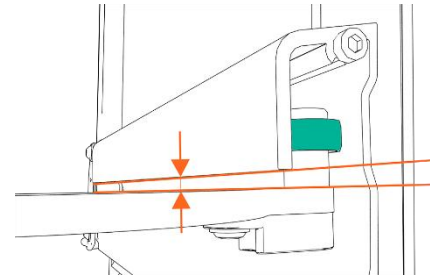

Figure 19: Distance between bottom lever and guiding rail

3.2.6 Bottom stopper

1. Check if the bottom stopper is present.
2. The bottom stopper is not worn or damaged.

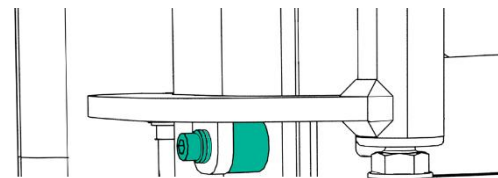

Figure 20: Bottom stopper

3.2.7 Catch block and door wedge

Apply power and pressure to the system and put the door(s) in closed position.



CAUTION!

Be aware the system could move when applying power and pressure to it.

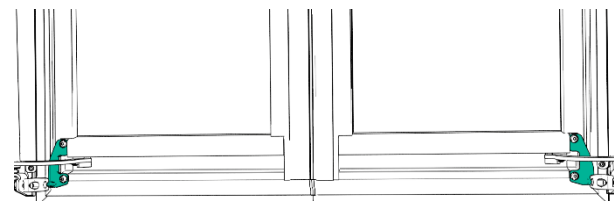

Figure 21: Door wedge and catch block locations

1. Check if the door wedge is caught by the catch block when the door is closed.
2. The catch block or door wedge are not worn or damaged.

NB! The block will be the part that wears out, because it is made of plastic, while the wedge is a steel part.



WARNING!

Remove the power and pressure from the system after executing this step and before continuing.

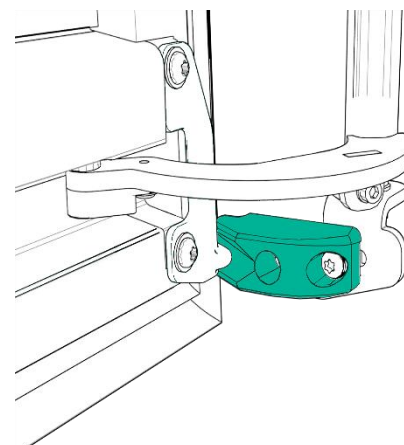

Figure 22: Check catch block

3.3 Parts inspections

These parts can get affected by use and must be readjusted or cleaned when needed. Check the distance settings of the door system in open and closed position following the installation manual.

3.3.1 Door shafts

- Check if the door shaft is free from vertical play. If the door shaft is free from vertical play, continue without executing this step. If there is play, execute the following checks.

1. Check the settings following the installation manual.
2. The bearing bush and pivot point at the top of the door shaft are not worn or damaged.
3. The bearing bush and pivot point at the bottom of the door shaft are not worn or damaged.

If no wear or damage is found, adjust the position of the top and/or bottom bracket according to the installation manual, until no more play is present.

Mind the gap between the bottom lever and the door rail: it must be kept at 4-8 mm.

3.3.2 Filter regulator

Check if the system is equipped with a regulator or a filter regulator. If there is no regulator or filter regulator, skip this step.

- Open drain by turning clockwise
- Close drain by turning counter clockwise

NOTICE

Depending on the filter regulator's location, it is advised to keep the drain closed so it will not spill dirt over vital parts of the vehicle.

1. Check if the pressure of the pneumatic system is 8 bar / 116 PSI.
2. The filter regulator is semi-automatic, meaning the filter will drain itself when the pneumatic pressure drops below 0.3 bar / 4.3 PSI and the drain is open. Manually drain the regulator every two months. This is done by turning the button at the bottom a quarter turn and pressing it.
3. Replace the filter when it is not clear white or at least once a year.

3.3.3 Tension steel cables

- Put the doors in appr. 70% open position.
 - Apply the tension meter as described by the manufacturer.
1. Check if the tension in the cable is 260-310 Newton.
 2. When using a sonic tension meter, the tension has to be 33-39 Hz for 1350 systems.

NB! This frequency only applies to 1350 systems.

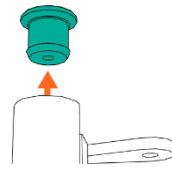

Figure 23: Top bearing door shaft

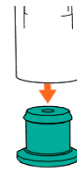

Figure 24: Bottom bearing door shaft

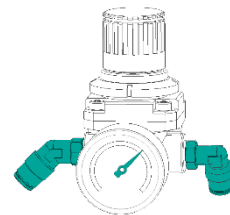

Figure 25: Regulator



Figure 26: Filter regulator

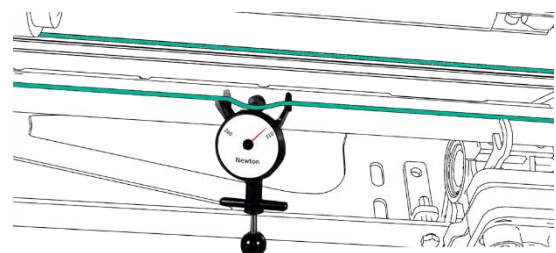

Figure 27: Tension meter

3.3.4 Grease bearing house

The bearing housings are greased before delivery. In some cases the bearing housing needs a refill.

NOTICE

If a grease refill is needed, do not use more than 20 g. When the bearing housing contains too much grease, the friction will hinder a smooth opening and closing of the doors.

- Check if the bearing housings run silently and smoothly over the guiding shaft.
- Check if there is a thin layer of grease on the guiding shaft.

If not, the grease must be refilled.

Do as follows:

- Insert 10 grams of grease in the bearing housing that runs dry.
- Move the doors from open to closed position a few times, then reassess whether one or both bearing housings need more grease: the shaft should now be a little greasy.

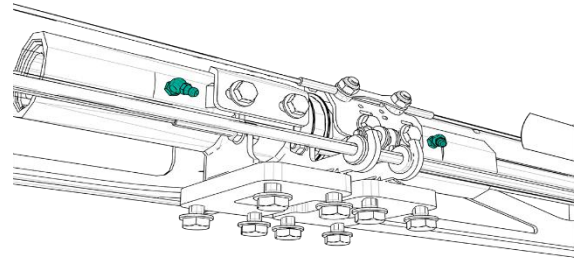

Figure 28: Grease bearing housing

NOTICE

Use "Arcanol MULTITOP" or a grease with similar specifications.

This grease is low temperature resistant. In case of low ambient temperatures, never use a general grease, risking damage to the bearings.

3.3.5 Grease spiral cable guiding shaft

Put the doors in open position.

1. The shaft is clean of dirt.
2. There is a layer of grease on the guiding shaft which helps the spiral cable run smoothly over the shaft.

Apply grease when needed. Use "Kroon Multi Purpose Lithep EP2" or a grease with similar specifications.

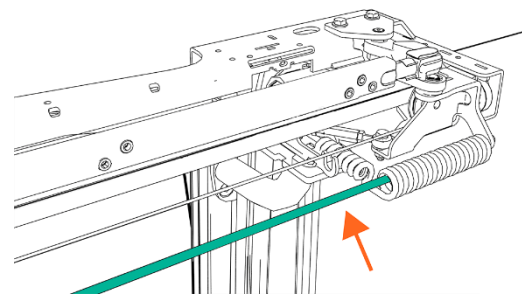

Figure 29: Spiral cable guiding shaft

3.3.6 Air leakage

Only check the leakage on door systems when the door is not functioning correctly or air leakage is hearable.

Check for damaged air tubes or connectors. Try to find where the leakage is coming from. Is there any air leak noise? Can you feel air coming from the connectors or tubes?

To reduce air leakage, manually drain the bowl following this maintenance manual's relevant chapter. Change the filter element inside the bowl at least every year.

In Appendix B, a comprehensive air leakage test is described.



4 Torque Settings

All door system settings that require torque tightening are given in this chapter. During maintenance, only fasteners mentioned below that have been loosened need to be tightened to torque. The torques of marked fasteners may be verified by checking if the marking is intact.

The fasteners which connect Ventura parts to the vehicle are, in most cases, not supplied by Ventura. Therefore the torque of these fasteners is not defined by Ventura.

After setting a part to torque specification, mark the connection with a torque marker.

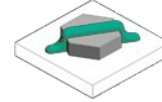

Figure 30: Torque marker

The position numbers in the image below correspond to the detailed drawings following, in which the required torque values are given.

In the detailed drawings, also the number of fasteners to be tightened is given.

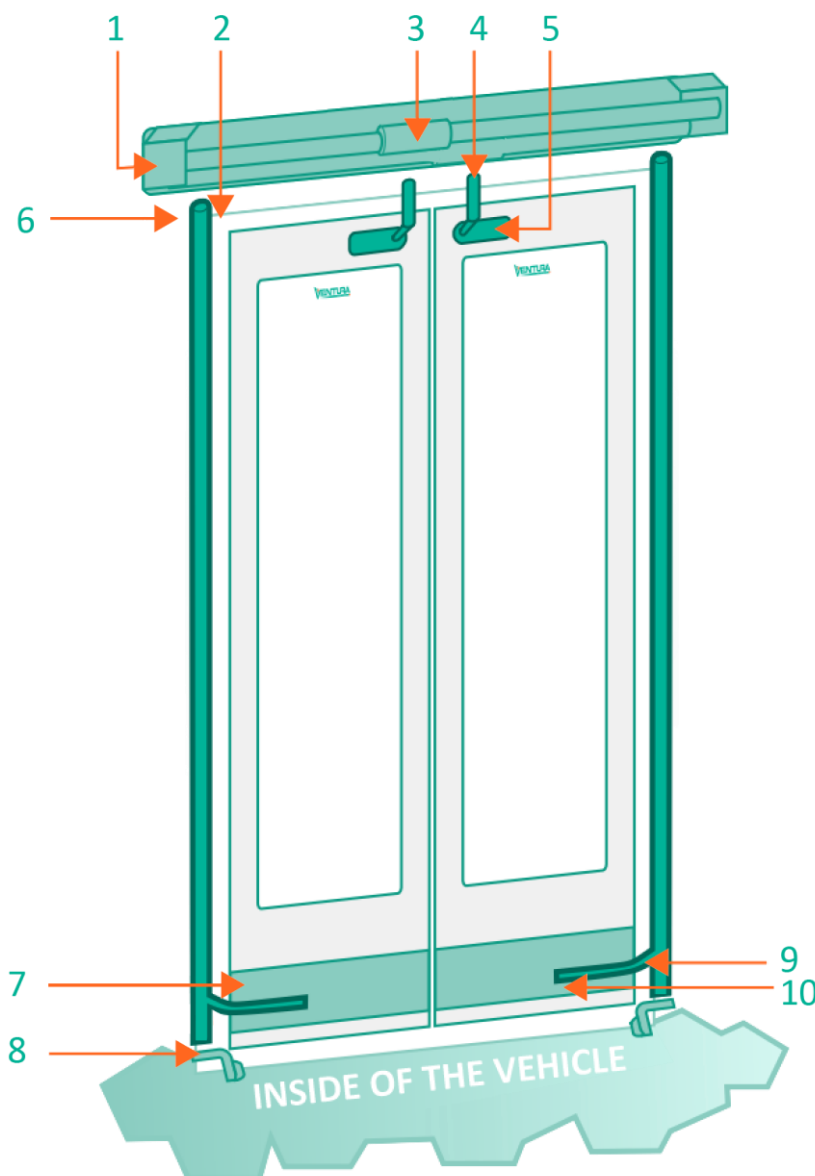
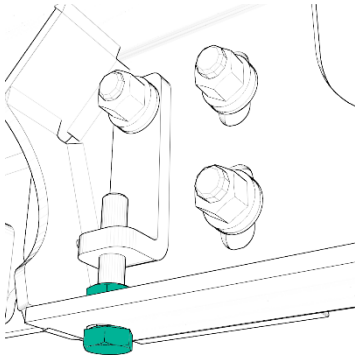

Figure 31: Torque setting overview



Position 1



22±2 Nm, 1 per side

Position 1

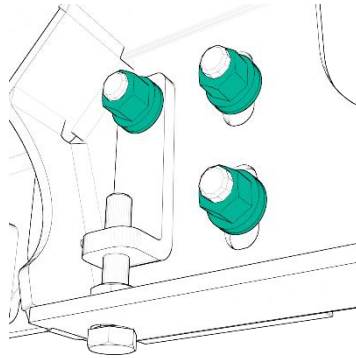

45±4 Nm, 3 per side

Position 2

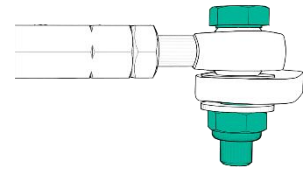

22±2 Nm, 1 per side

Position 2

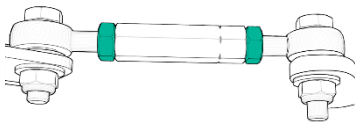

18±2 Nm, 2 per side

Position 3

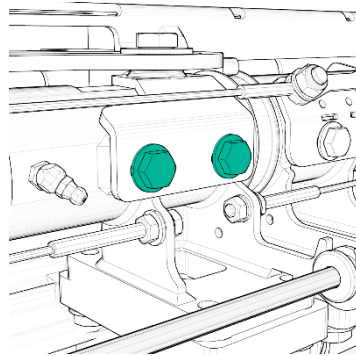

22±2 Nm, 2 pcs

Position 4

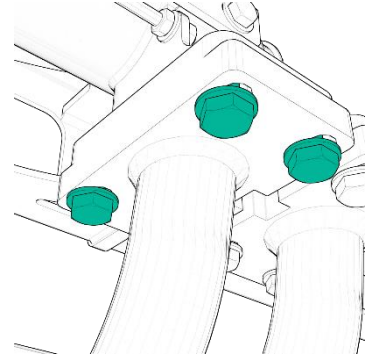

45±4 Nm, 4 per side

Position 5

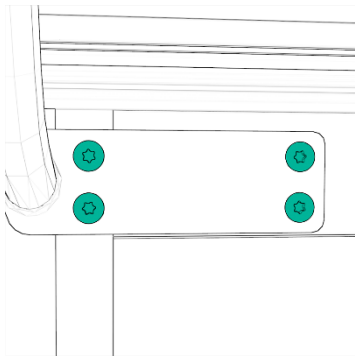

59±5 Nm, 4 per side

Position 6

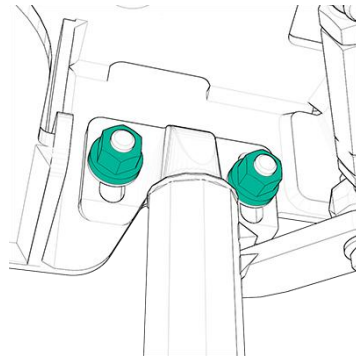

22±2 Nm, 2 per side

Position 7

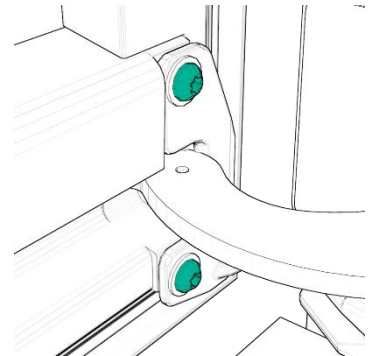

26±2 Nm, 2 per side

Position 8

If fasteners are supplied by Ventura

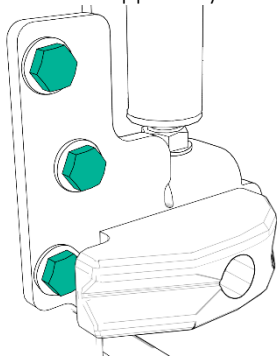

22±2 Nm, 2 per side

Position 8

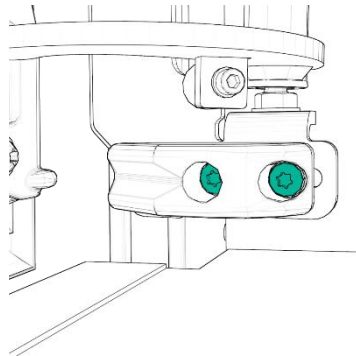

20±2 Nm, 2 per side

Position 9

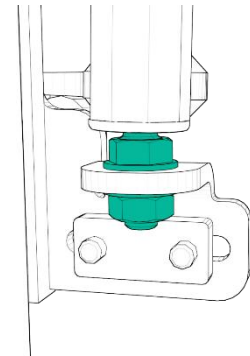

45±4 Nm, 1 per side

Continue on the next page.



Position 10

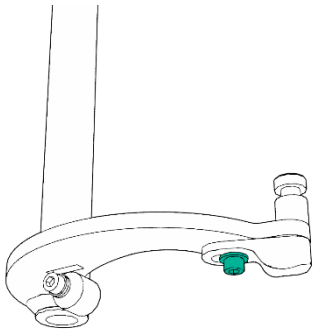

Loctite 243 on the bolt.
 6 ± 1 Nm, 1 per side



5 Operational checks

5.1 General checks before power

Execute these checks before applying power.



WARNING!

Applying power to an unchecked system may result in a hazardous situation causing death or serious injury.

No.	Check	Verified by	Approved
1.	Be assured all fasteners are on torque where required according to the installation manual. If not, tighten them to torque.		
2.	Check if all cables and tubes on the system are connected.		
3.	Manually check if the door leaf/leaves open and close without obstruction.		
4.	It is not permitted to attach and/or tie external cabling and/or piping to the door mechanism.		

5.2 Operation and controls

These checks are all with power and pressure.

No.	Check	Verified by	Approved
1.	There is no leakage in the pneumatic system, in closed and open position of the door system.		
2.	Check if the electric parts and wires, as well as the pneumatic tubes and components, are not damaged, possibly risking short circuiting or air leakage.		
3.	Check if all door system settings, in closed and open position and while closing and opening, match the installation manual's requirements.		
4.	When opening and closing the door system, check that the door mechanism, door shafts and door leaves run clear of external vehicle parts such as wiring, piping and support rods.		
5.	After resolving all DTCs, clear all fault codes from the DCU (if applicable).		

5.3 Safety checks

These checks are all with power and pressure.

No.	Check	Verified by	Approved
1.	All emergency buttons function as specified.		
2.	Apply an obstruction while closing. Doors open again. Test left and right separately. *CAUTION!		
3.	Apply an obstruction while opening. Doors go to half open position. Test left and right separately. *CAUTION!		
4.	Check if the mechanism goes over center in closed position (if applicable). The over center lever at the left in the mechanism must touch the end stop.		



CAUTION!

Do not use body parts to apply an obstruction.

Appendix A - Contact

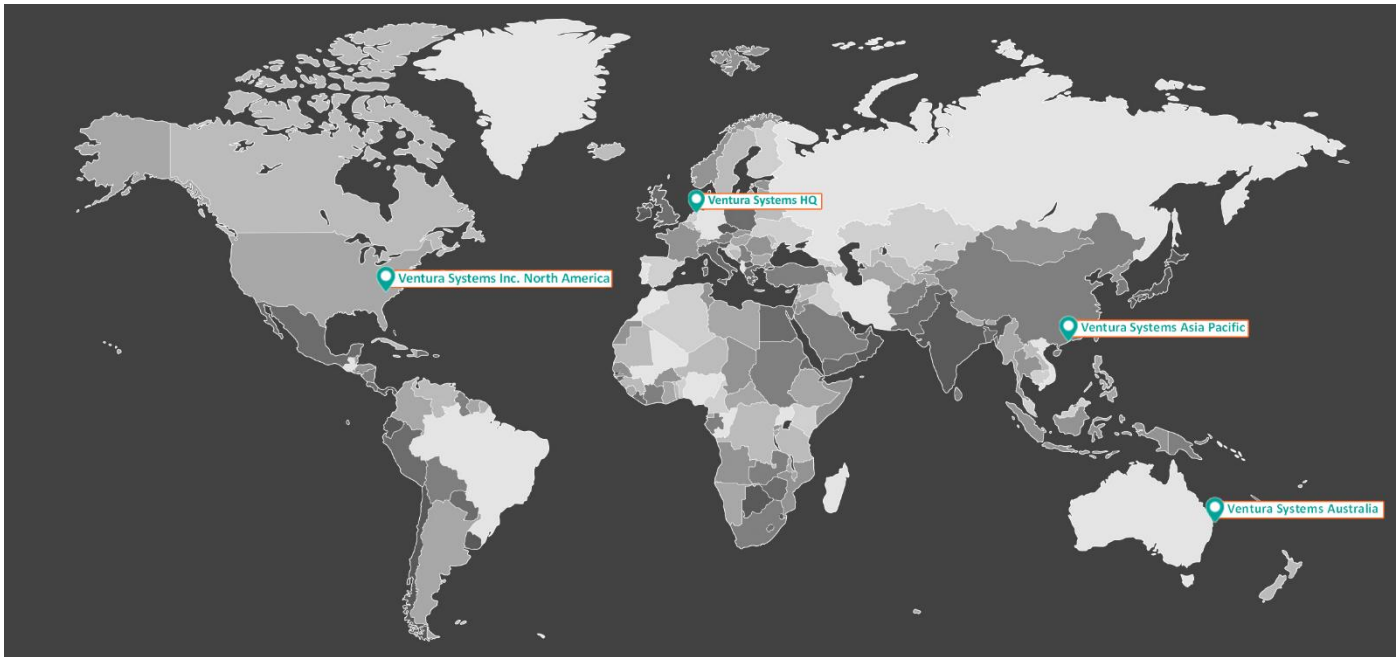

Figure 32: World map Ventura locations





Ventura Systems HQ	Ventura Systems Asia Pacific
 De Marne 216 8701 MH Bolsward The Netherlands	Unit 10 on the 13/F Fotan Industrial Centre 26-28 Au Pui Wan Street Hong Kong
 +31 515 577750	+852 2712 6001
 support@venturasystems.com parts@venturasystems.com	ABBSupport@venturasystems.hk
 www.venturasystems.com	www.venturasystems.com

Table 8: General contact and parts information HQ and Asia Pacific





Ventura Systems Australia	Ventura Systems Inc North America
 3/176 Siganto Drive QLD 4212 Helensvale Australia	160 Gibson Ct NC 28034 Dallas
 +61 474 031074	+1 704-691-0311
 AUSSupport@venturasystems.com.au	support.inc@venturasystems.com
 www.venturasystems.com	www.venturasystems.com

Table 9: General contact and parts information Australia and North America

Contact your local agent for parts.

Appendix B - Air leakage test

All stated air leakage test values are applicable solely on one door system. Starting pressure of the test is 8 bars, test time is one minute.

The leakage value is a constant indicator in testing supplied pneumatic parts.

Cylinder type	Air leakage value (bar)
Common cylinder	0.1
Rodless cylinder	1.0

Table 10: Air leakage values

The following explanation uses icons how to connect the manometer. The icons used are displayed in the legend.

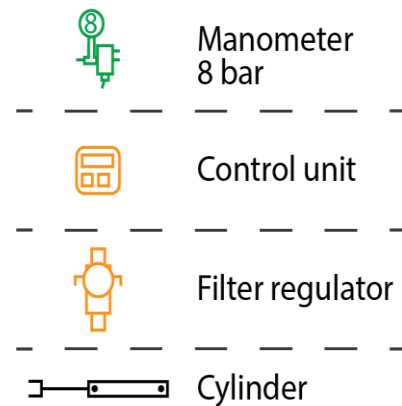

Figure 33: Legend for air leakage images

Testing the complete door system

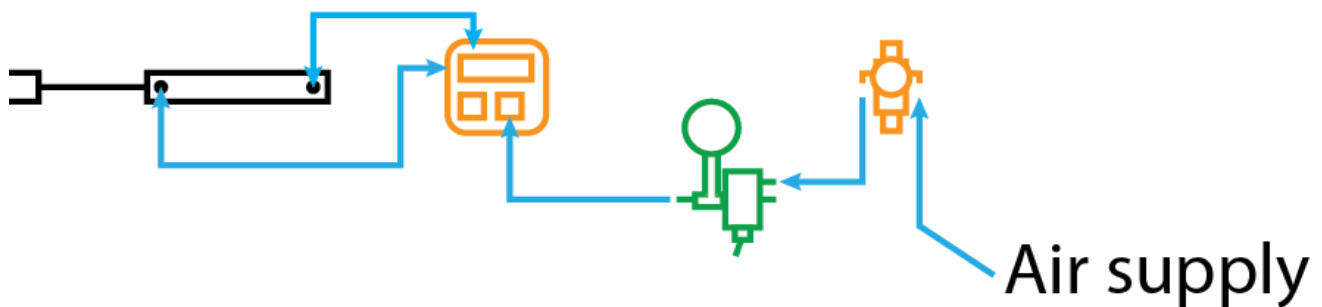

Figure 34: Testing complete door system

1. Connect the testing device between the filter regulator and the rest of the door system as shown in the image above.
2. Start the engine of the vehicle, air pressure should be 8 bar.
3. Let go of the air pressure at the filter regulator.
4. Set the test device on "open".
5. Turn up the air pressure at the filter regulator till 8 bar.
6. Turn on the manometer at the testing device by pressing the left button and check the pressure.
7. Set the test device on "testing".
8. Measure the pressure drop for 1 minute in open position, the value from 8 bar should not drop more than 1 bar. Repeat this for the closed position.
9. Set the test device on "open".
10. Let go of the air pressure at the filter regulator.
11. Remove the testing device and fit the air tubes in their original state.
12. Turn up the air pressure at the filter regulator till 8 bar.
13. If the value drops more than 1 bar in one minute, contact Ventura Support.

Testing door open

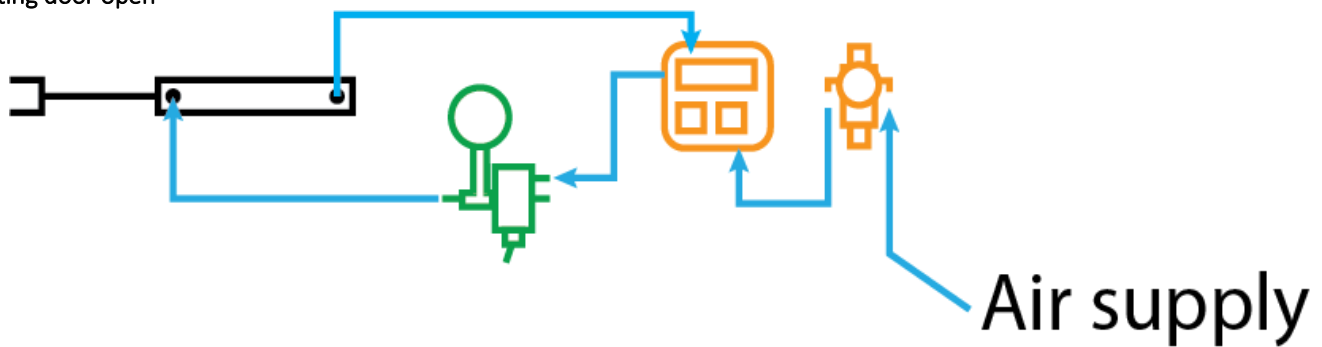

Figure 35: Testing door open position

1. Connect the testing device between the closed position of the cylinder and the rest of the door system as shown in the image above.
2. Start the engine of the vehicle, air pressure should be 8 bar.
3. Close the door.
4. Set the test device on "open".
5. Open the door.
6. Turn on the manometer at the testing device by pressing the left button and check the pressure.
7. Set the testing device on "testing"
8. Measure the pressure drop for one minute in open position. The value of 8 bar should not drop more than 1 bar.
9. Set the testing device on "open".
10. Close the door.
11. Remove the testing device and fit the air tubes in their original state.

Testing door closed

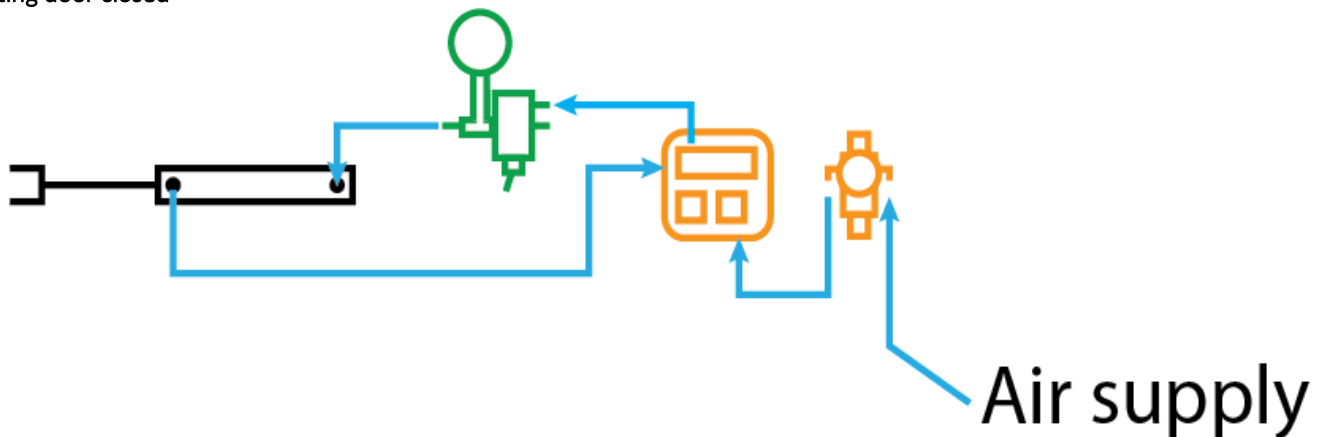

Figure 36: Testing door closed position

1. Connect the testing device between the open position of the cylinder and the rest of the door system as shown in the image above.
2. Start the engine of the vehicle, air pressure should be 8 bar.
3. Open the door.
4. Set the test device on "open".
5. Close the door.
6. Turn on the manometer at the testing device by pressing the left button and check the pressure.
7. Set the testing device on "testing"
8. Measure the pressure drop for one minute in open position. The value of 8 bar should not drop more than 1 bar.
9. Set the testing device on "open".
10. Open the door.
11. Remove the testing device and fit the air tubes in their original state.

Appendix C - Maintenance checklist

Cycles assumption	Minimal maintenance	Applicable for
300.000	Every 12 months	Wear parts
300.000	Every 12 months	Parts inspection

Inspection date	
Vehicle Nr.	
Door Nr.	

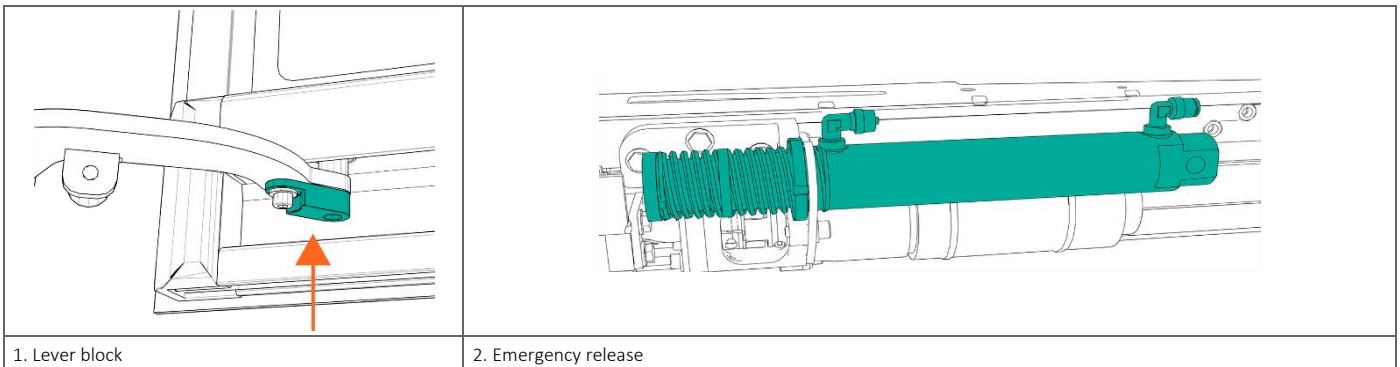

Item	Checked	Any defects		Resolved	Date	Signature
		Yes	No			
1. Lever block	<input type="checkbox"/>	<input type="checkbox"/>	<input type="checkbox"/>	<input type="checkbox"/>		
2. Emergency release	<input type="checkbox"/>	<input type="checkbox"/>	<input type="checkbox"/>	<input type="checkbox"/>		

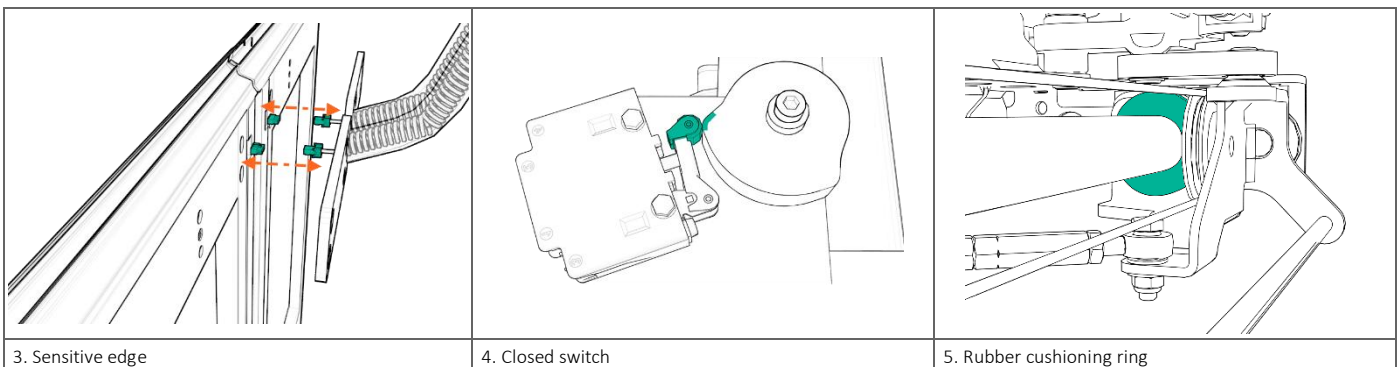

Item	Checked	Any defects		Resolved	Date	Signature
		Yes	No			
3. Sensitive edge	<input type="checkbox"/>	<input type="checkbox"/>	<input type="checkbox"/>	<input type="checkbox"/>		
4. Closed switch	<input type="checkbox"/>	<input type="checkbox"/>	<input type="checkbox"/>	<input type="checkbox"/>		
5. Rubber cushioning ring	<input type="checkbox"/>	<input type="checkbox"/>	<input type="checkbox"/>	<input type="checkbox"/>		

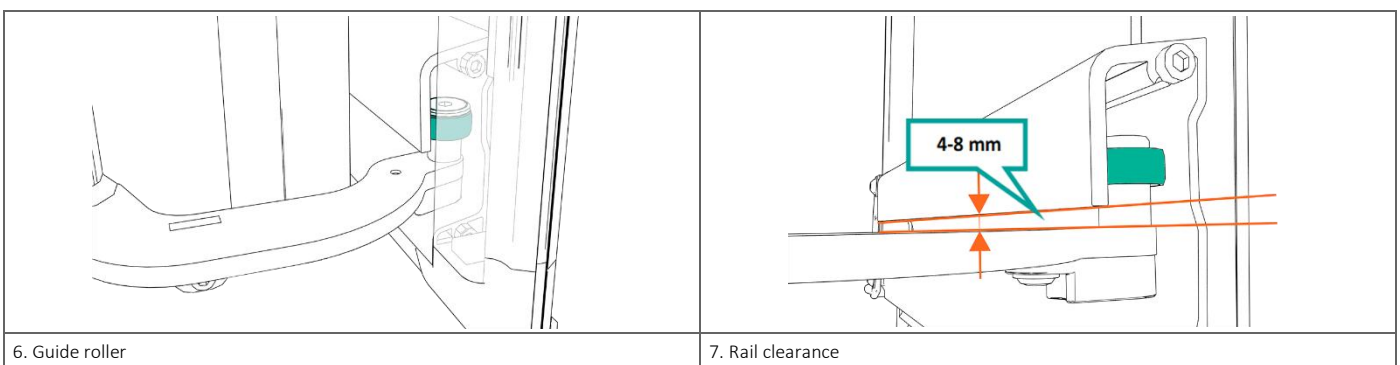

Item	Checked	Any defects		Resolved	Date	Signature
		Yes	No			
6. Guide roller	<input type="checkbox"/>	<input type="checkbox"/>	<input type="checkbox"/>	<input type="checkbox"/>		
7. Rail clearance	<input type="checkbox"/>	<input type="checkbox"/>	<input type="checkbox"/>	<input type="checkbox"/>		

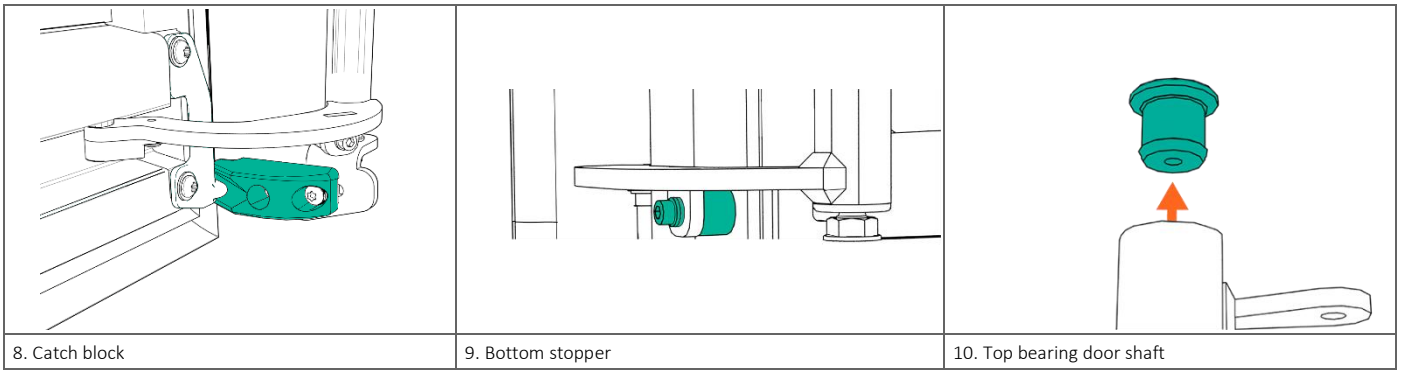

Item	Checked	Any defects		Resolved	Date	Signature
		Yes	No			
8. Catch block	<input type="checkbox"/>	<input type="checkbox"/>	<input type="checkbox"/>	<input type="checkbox"/>		
9. Bottom stopper	<input type="checkbox"/>	<input type="checkbox"/>	<input type="checkbox"/>	<input type="checkbox"/>		
10. Top bearing	<input type="checkbox"/>	<input type="checkbox"/>	<input type="checkbox"/>	<input type="checkbox"/>		

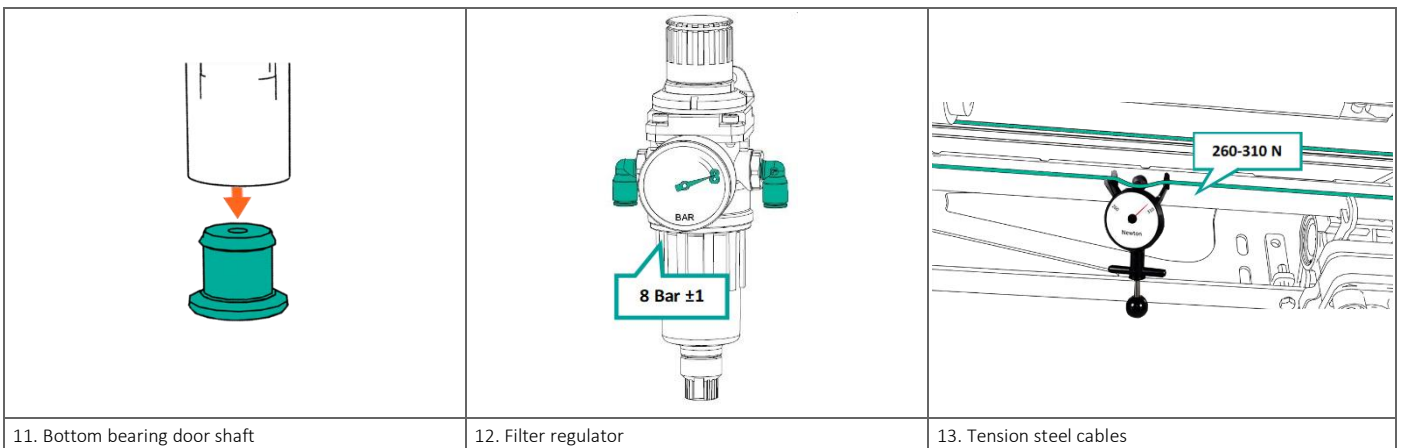

Item	Checked	Any defects		Resolved	Date	Signature
		Yes	No			
11. Bottom bearing	<input type="checkbox"/>	<input type="checkbox"/>	<input type="checkbox"/>	<input type="checkbox"/>		
12. Filter regulator	<input type="checkbox"/>	<input type="checkbox"/>	<input type="checkbox"/>	<input type="checkbox"/>		
13. Cable tension	<input type="checkbox"/>	<input type="checkbox"/>	<input type="checkbox"/>	<input type="checkbox"/>		

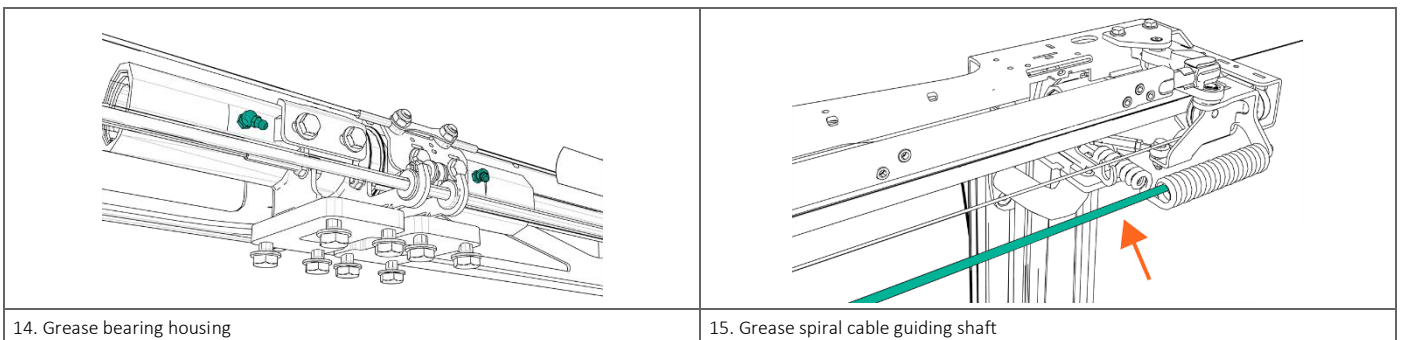

Item	Checked	Any defects		Resolved	Date	Signature
		Yes	No			
14. Grease bearing housing	<input type="checkbox"/>	<input type="checkbox"/>	<input type="checkbox"/>	<input type="checkbox"/>		
15. Grease shaft	<input type="checkbox"/>	<input type="checkbox"/>	<input type="checkbox"/>	<input type="checkbox"/>		

General checks before power

Item	Checked	Any defects		Resolved	Signature
		Yes	No		
Be assured all fasteners are on torque where required according to the installation manual. If not, tighten them to torque.	<input type="checkbox"/>	<input type="checkbox"/>	<input type="checkbox"/>	<input type="checkbox"/>	
Check if all cables and tubes on the system are connected.	<input type="checkbox"/>	<input type="checkbox"/>	<input type="checkbox"/>	<input type="checkbox"/>	
Manually check if the door leaf/leaves open and close without obstruction.	<input type="checkbox"/>	<input type="checkbox"/>	<input type="checkbox"/>	<input type="checkbox"/>	

Operations and controls

Item	Checked	Any defects		Resolved	Signature
		Yes	No		
There is no leakage in the pneumatic system, in closed and open position of the door system.	<input type="checkbox"/>	<input type="checkbox"/>	<input type="checkbox"/>	<input type="checkbox"/>	
Check if the electric parts and wires, as well as the pneumatic tubes and components, are not damaged, possibly risking short circuiting or air leakage.	<input type="checkbox"/>	<input type="checkbox"/>	<input type="checkbox"/>	<input type="checkbox"/>	
Check if all door system settings, in closed and open position and while closing and opening, match the installation manual's requirements.	<input type="checkbox"/>	<input type="checkbox"/>	<input type="checkbox"/>	<input type="checkbox"/>	
For systems containing potentiometers: in closed position, the potentiometer voltage(s) must be between 1.5 and 3.5 V. Aim for 2.5 V.	<input type="checkbox"/>	<input type="checkbox"/>	<input type="checkbox"/>	<input type="checkbox"/>	

Safety checks

Item	Checked	Any defects		Resolved	Signature
		Yes	No		
All emergency buttons function as specified.	<input type="checkbox"/>	<input type="checkbox"/>	<input type="checkbox"/>	<input type="checkbox"/>	
Apply an obstruction while closing. Door system opens again. If applicable: test left and right separately. Caution: do not use body parts to apply an obstruction.	<input type="checkbox"/>	<input type="checkbox"/>	<input type="checkbox"/>	<input type="checkbox"/>	
Apply an obstruction while opening. Door system goes to half open position or power is switched off. If applicable: test left and right separately. Caution: do not use body parts to apply an obstruction.	<input type="checkbox"/>	<input type="checkbox"/>	<input type="checkbox"/>	<input type="checkbox"/>	
Check if the mechanism goes over center in closed position (if applicable). The over center lever in the mechanism must touch the end stop.	<input type="checkbox"/>	<input type="checkbox"/>	<input type="checkbox"/>	<input type="checkbox"/>	